

未经授权
禁止转载外传

3-1 选择与三视图相对应的轴测图，将其编号填入圆圈内

(机工中职2版) 机械制图习题集

3-1-1

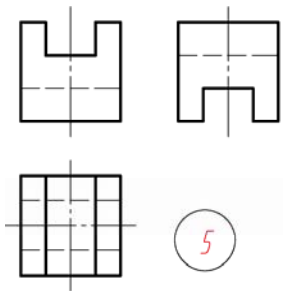

5



(1)



(2)



(3)



(4)



(5)



(6)

3-1-2

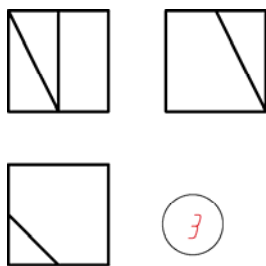

3

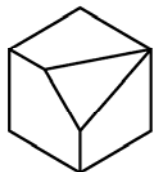

(1)

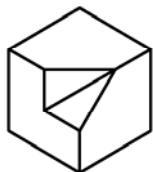

(2)

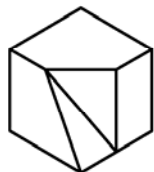

(3)

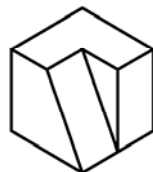

(4)



(5)

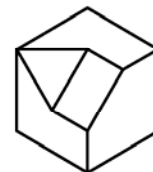

(6)

3-1-3

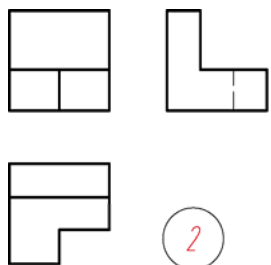

2



(1)



(2)



(3)

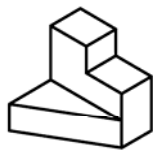

(4)



(5)

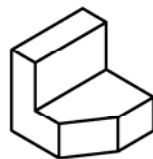

(6)

3-2-1

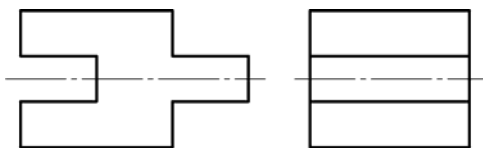

①

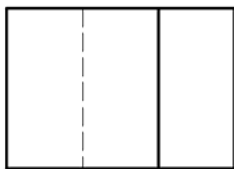

② ✓

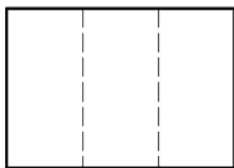

③

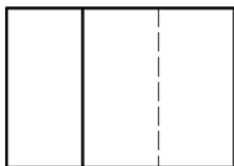

④

3-2-2

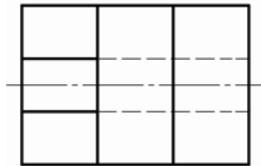
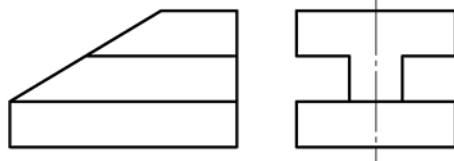

①

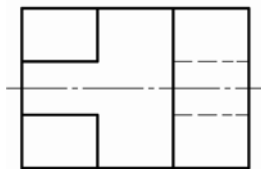

②

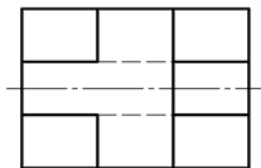

③

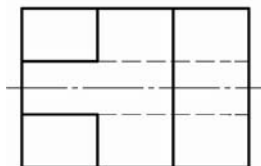

④ ✓

未经授权
禁止转载外传

3-2-3

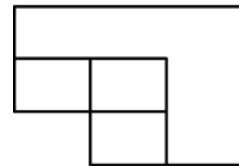
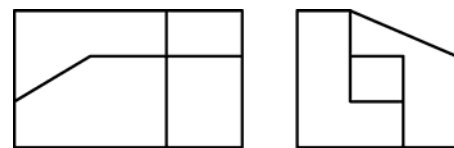

①

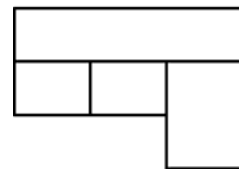

② ✓

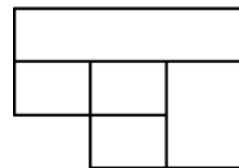

③

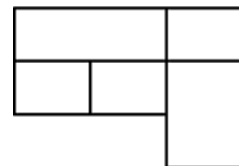

④

3-3-1

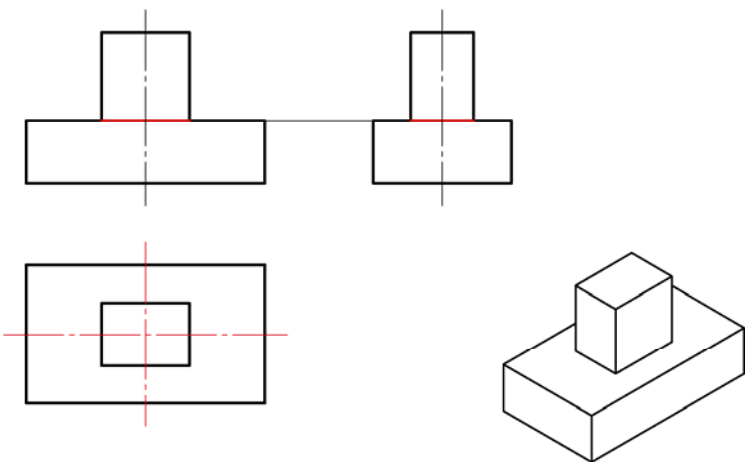

3-3-2

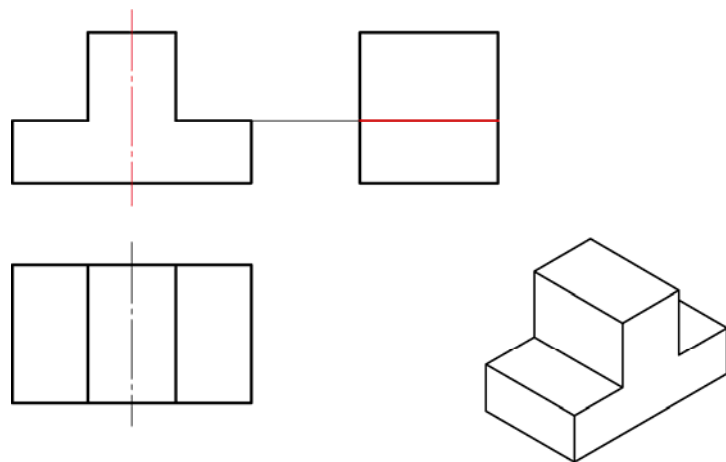

3-3-3

未经授权
禁止转载外传

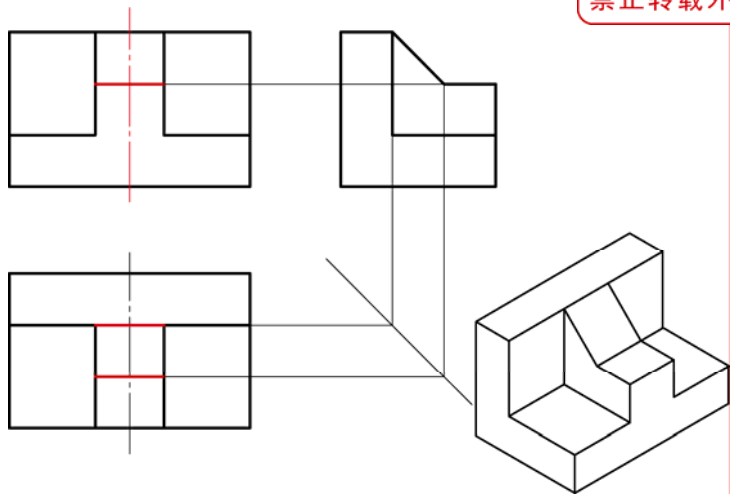

3-3-4

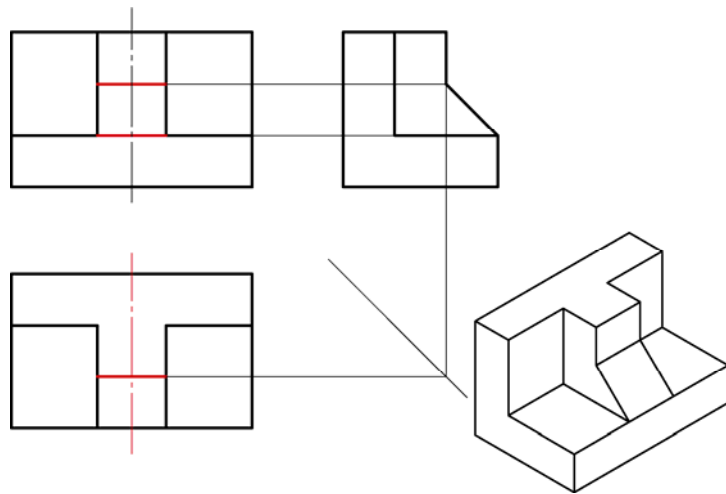

3-4-1

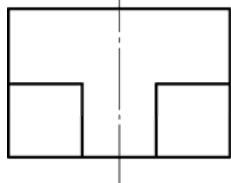
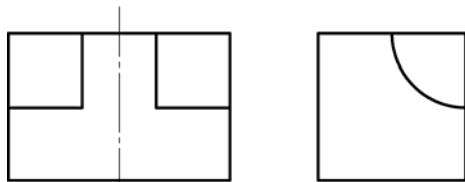

正确、~~错误~~

未经授权
禁止转载外传

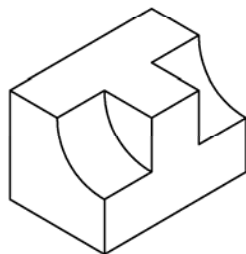

3-4-2

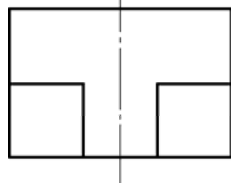
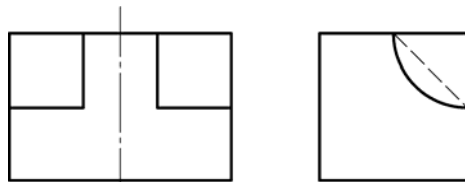

~~正确~~、错误

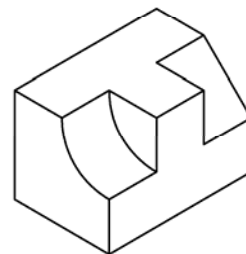

3-4-3

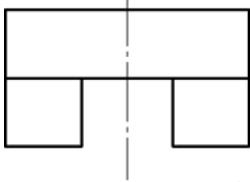
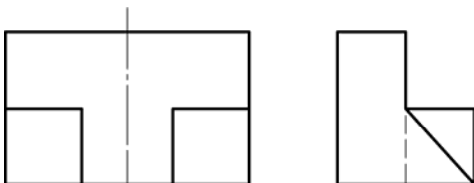

~~正确~~、错误

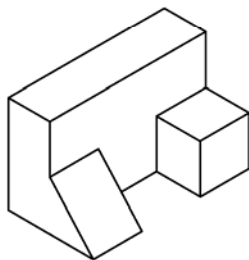

3-4-4

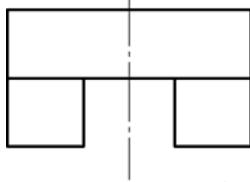
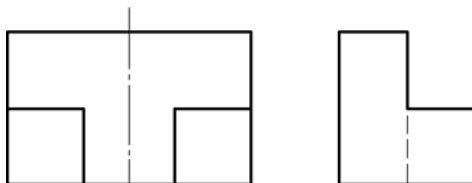

正确、~~错误~~

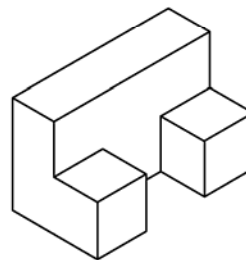

3-5-1

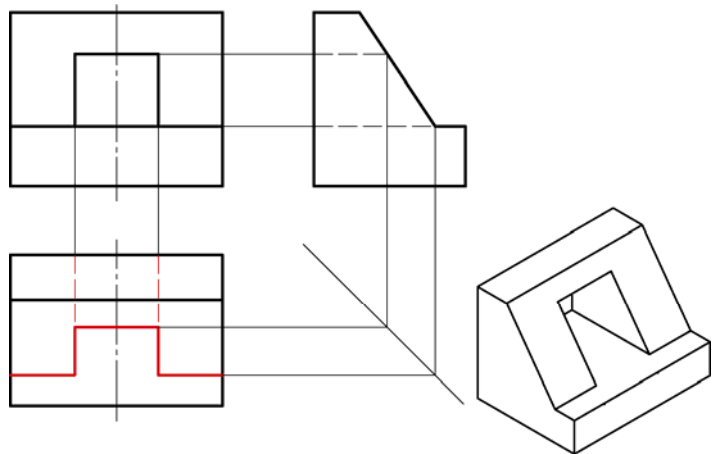

3-5-2

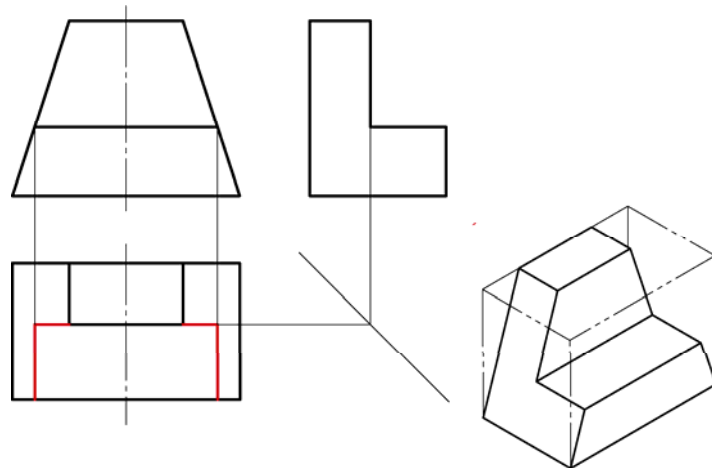

3-5-3

未经授权
禁止转载外传

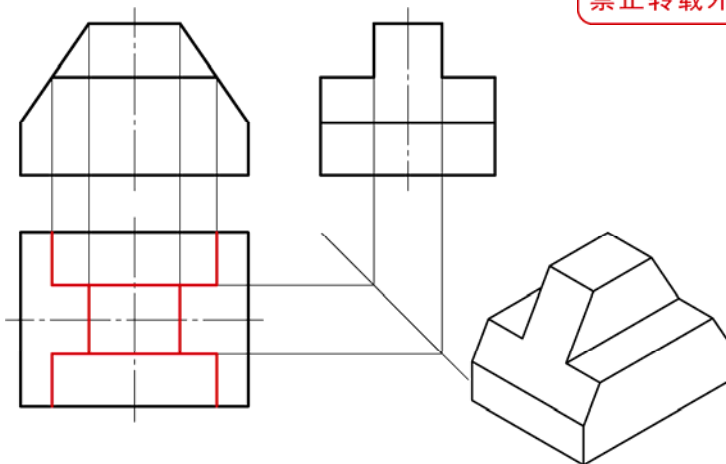

3-5-4

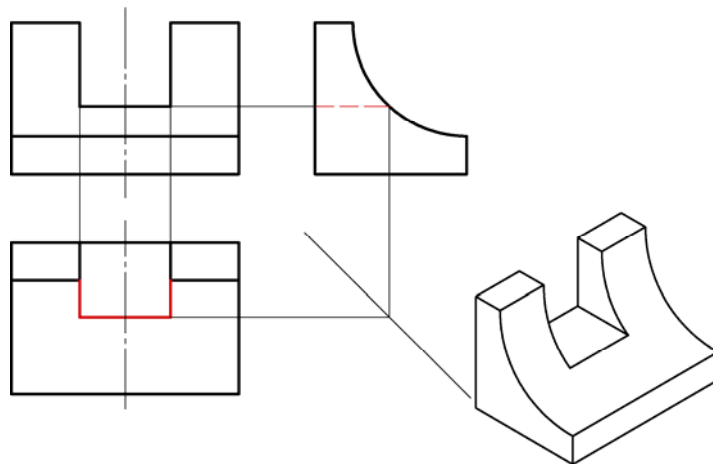

3-6-1 补画左视图 (保留投影连线)。

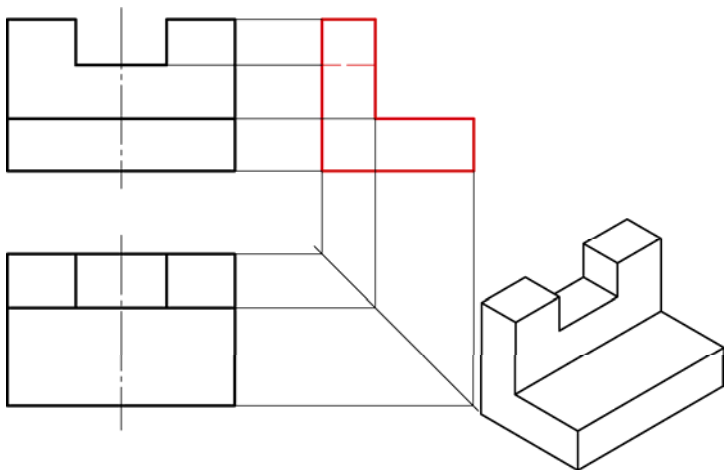

3-6-2 补画左视图 (保留投影连线)。

未经授权
禁止转载外传

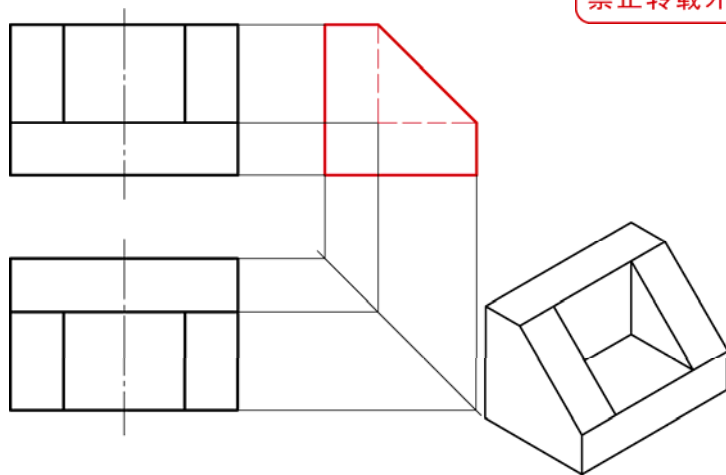

3-6-3 补画主视图 (保留投影连线)。

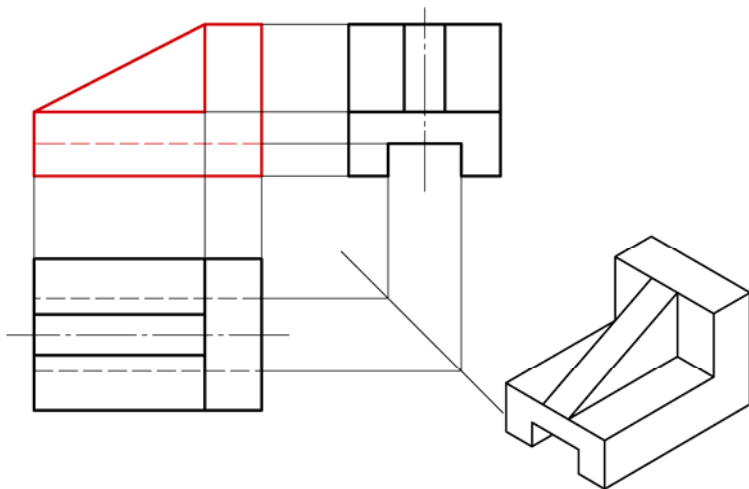

3-6-4 补画左视图 (保留投影连线)。

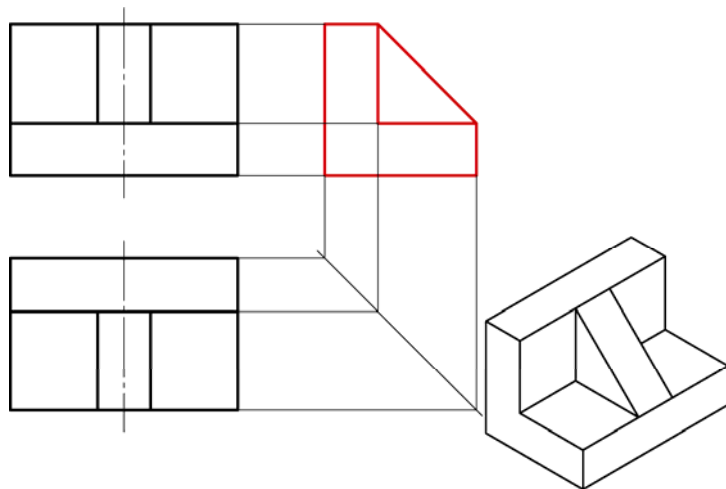

3-7-1

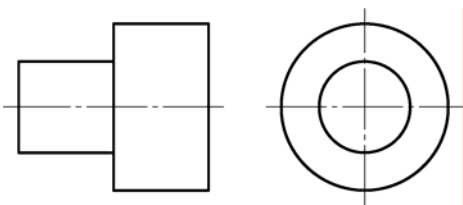

圆柱与圆柱同轴叠加

3-7-2

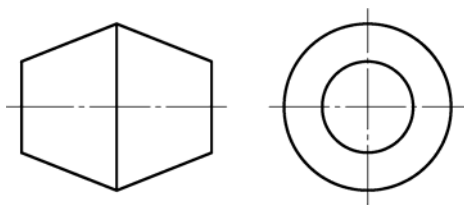

圆台与圆台同轴叠加

3-7-3

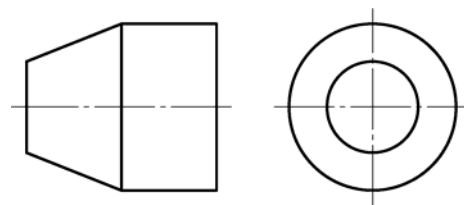

圆台与圆柱同轴叠加

3-7-4

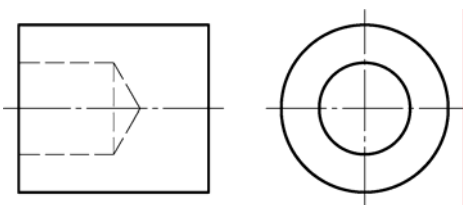

在圆柱中挖掉圆柱和圆锥

3-7-5

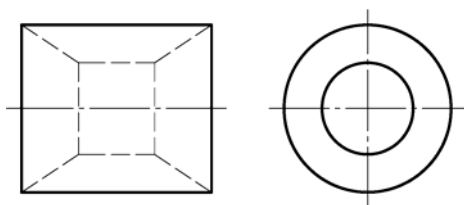

在圆柱中挖掉圆台、圆柱和圆台

3-7-6

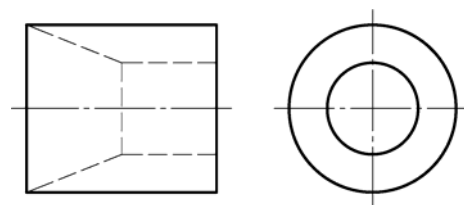

在圆柱中挖掉圆台和圆柱

3-7-7

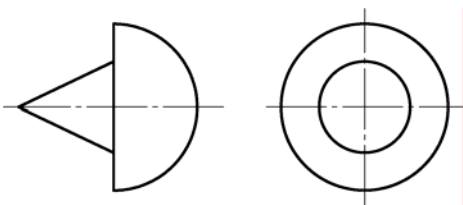

圆锥与半圆球同轴叠加

3-7-8

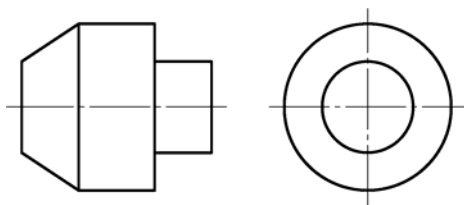

小圆柱与大圆柱、圆台同轴叠加

3-7-9

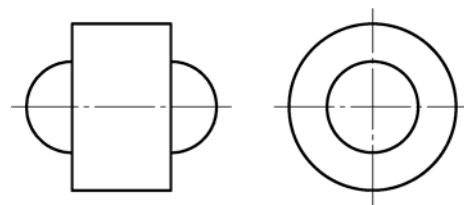

半圆球与圆柱、半圆球同轴叠加

3-8-1 主视图外轮廓相同，但轮廓内应有差异——补画主视图中所缺的图线。

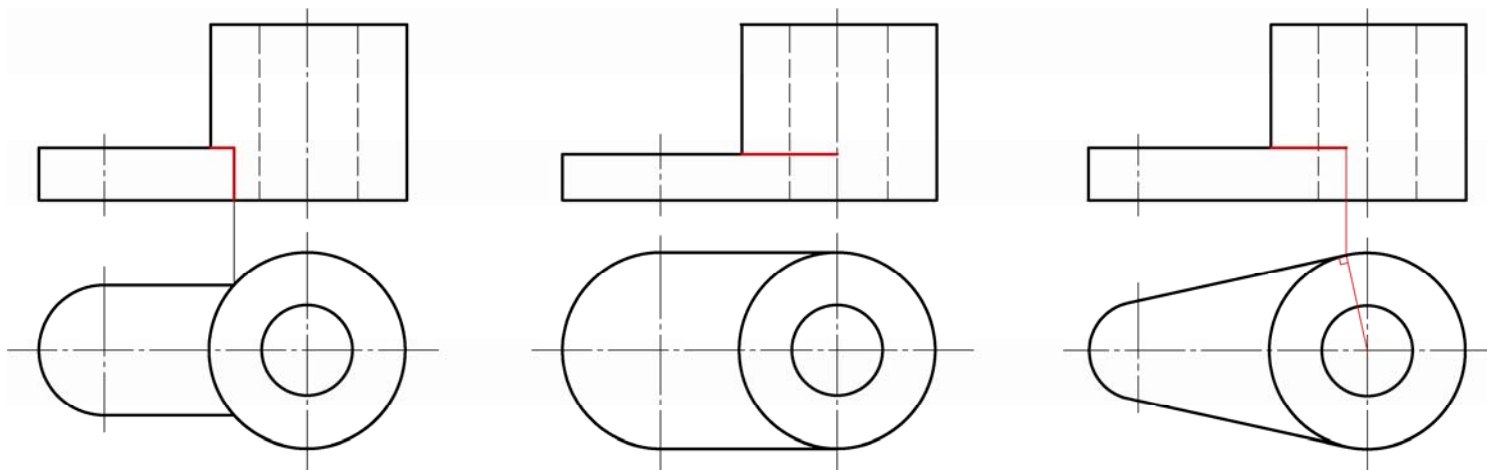

3-8-2 主视图外轮廓相同，但轮廓内应有差异——补画主视图中所缺的图线。

未经授权
禁止转载外传

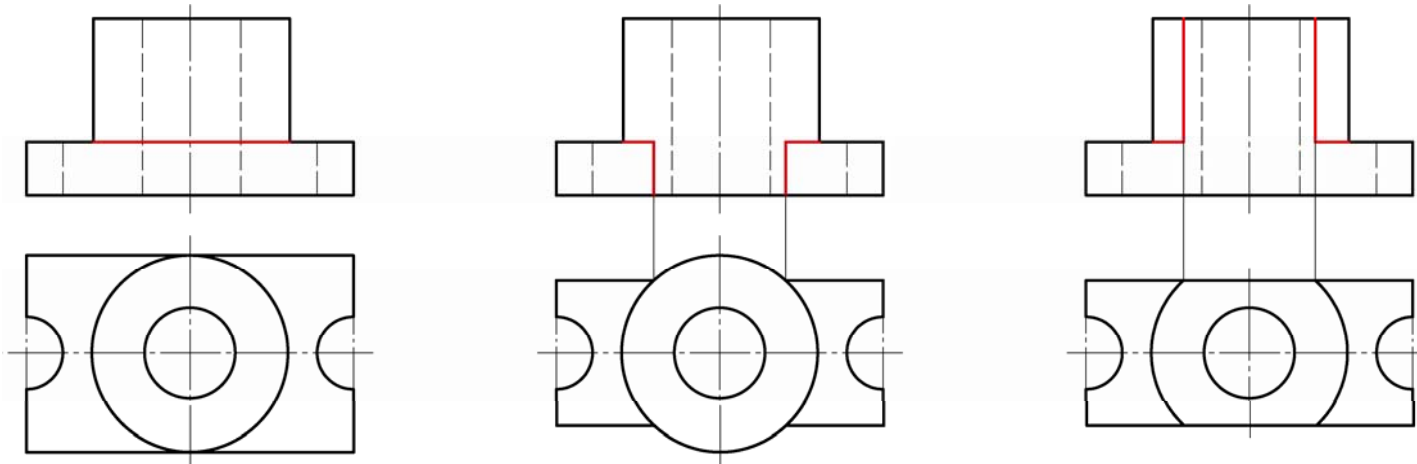

3-9-1

未经授权
禁止转载外传

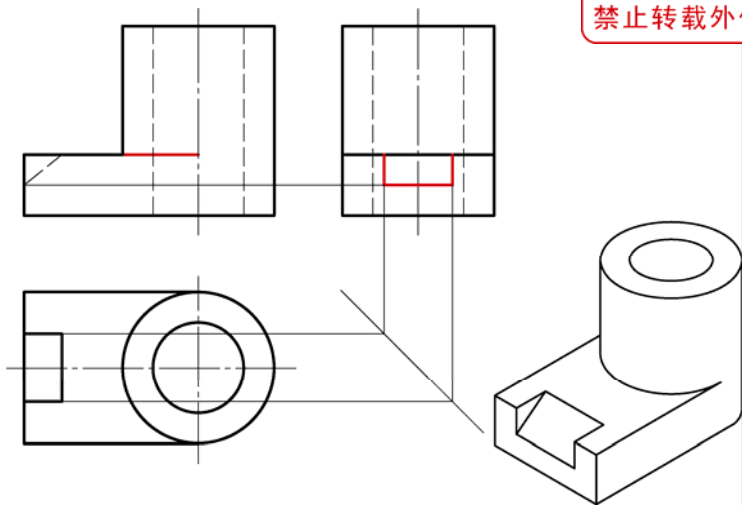

3-9-2

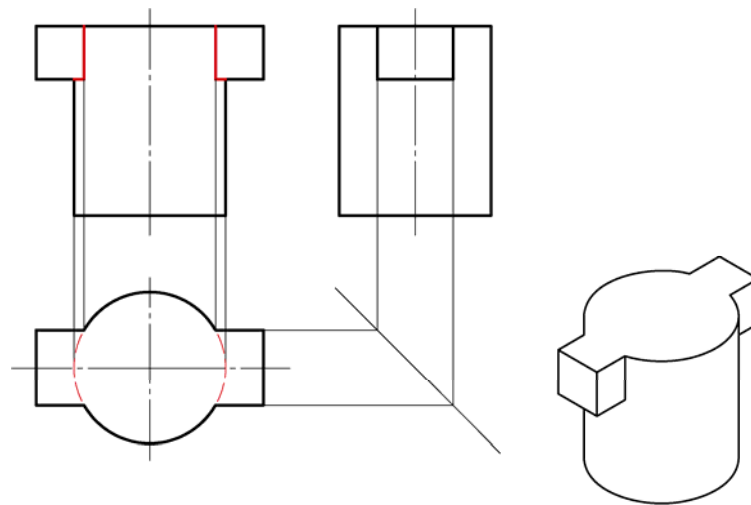

3-9-3

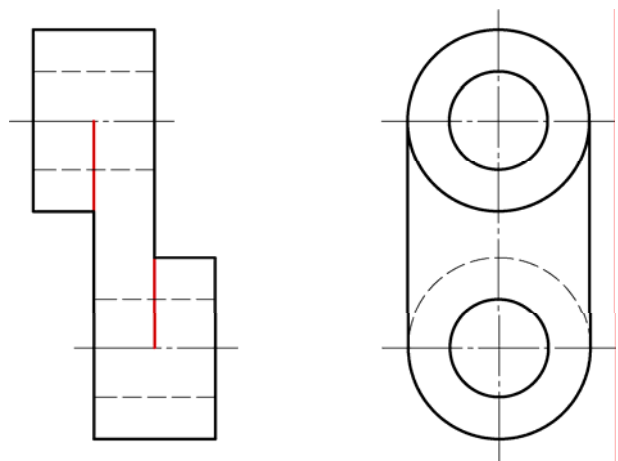

3-9-4

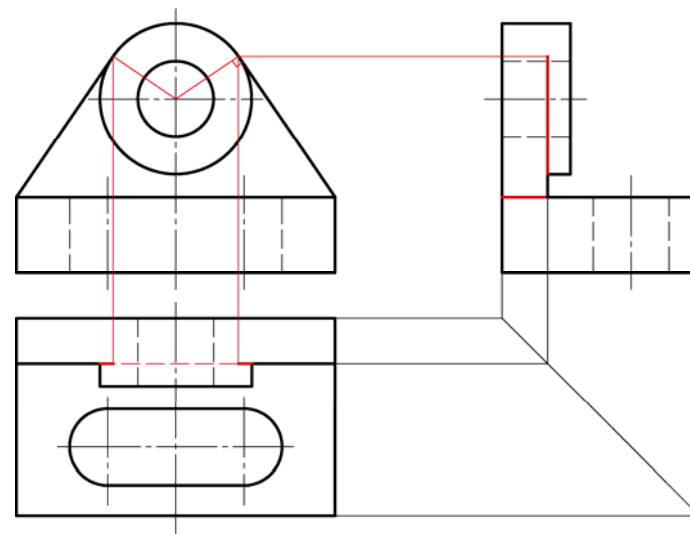

3-10-1

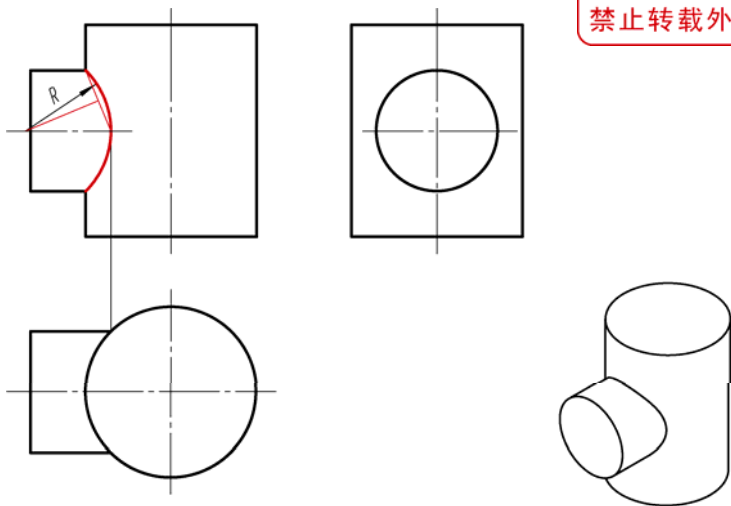

未经授权
禁止转载外传

3-10-2

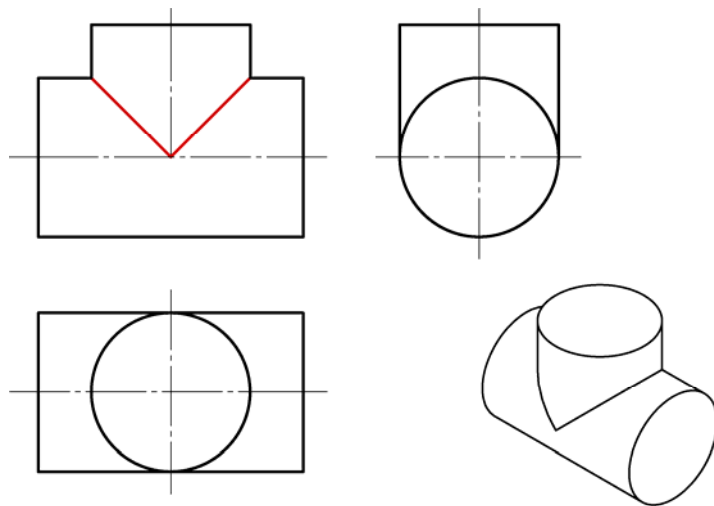

3-10-3

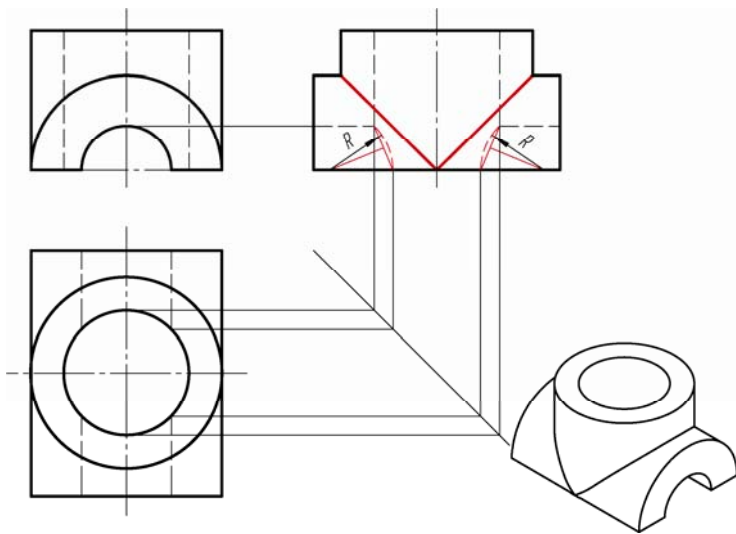

3-10-4

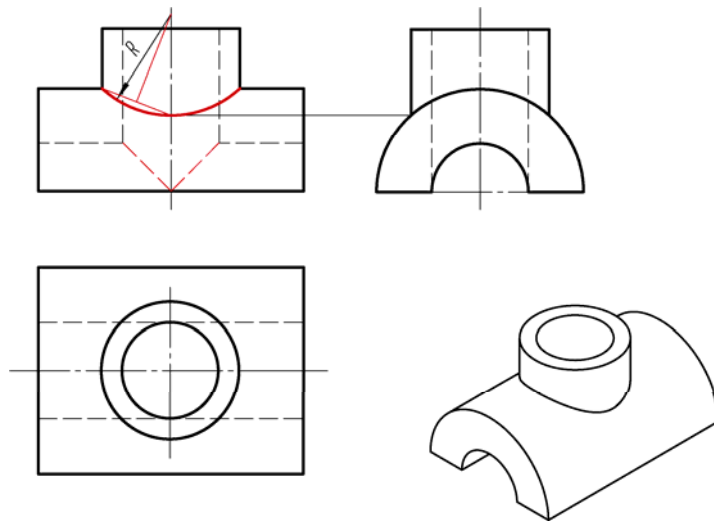

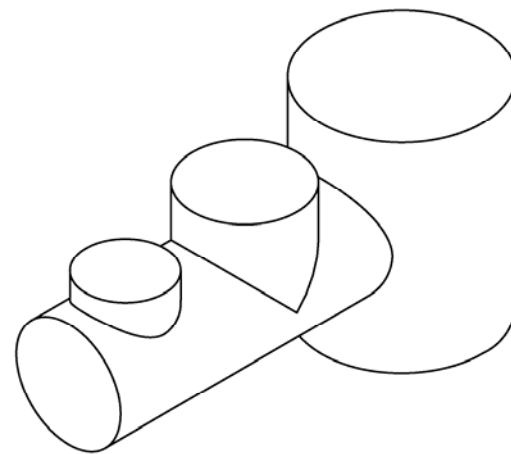
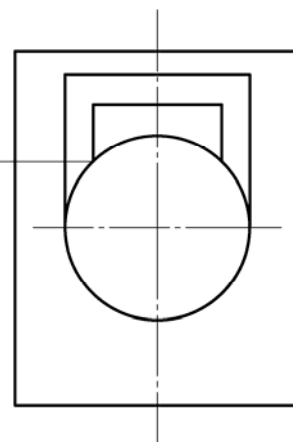
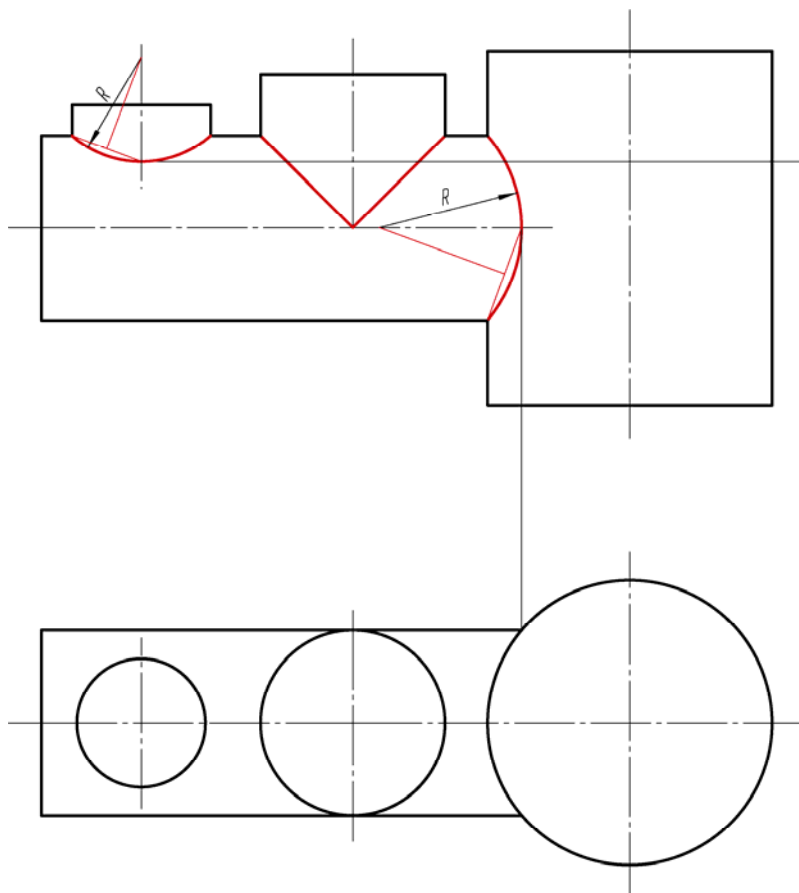

未经授权
禁止转载外传

3-12-1 将标注错误的尺寸打×；修改标注不妥的尺寸。

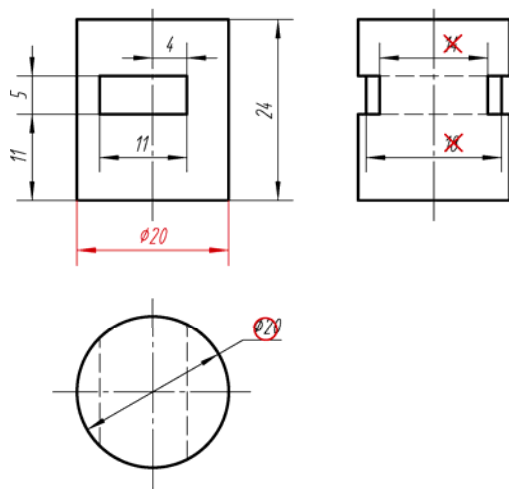

3-12-2 将标注错误的尺寸打×；修改标注不妥的尺寸。

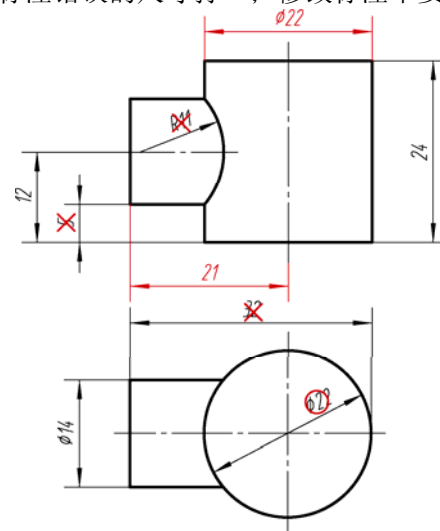

未经授权
禁止转载外传

3-12-3 将标注错误的尺寸打×；修改标注不妥的尺寸。

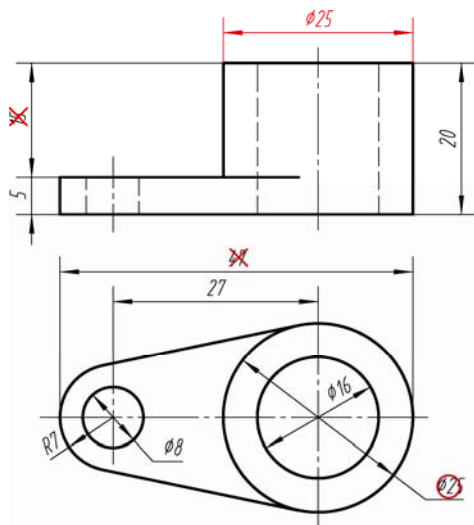

3-12-4 将标注错误的尺寸打×；修改标注不妥的尺寸。

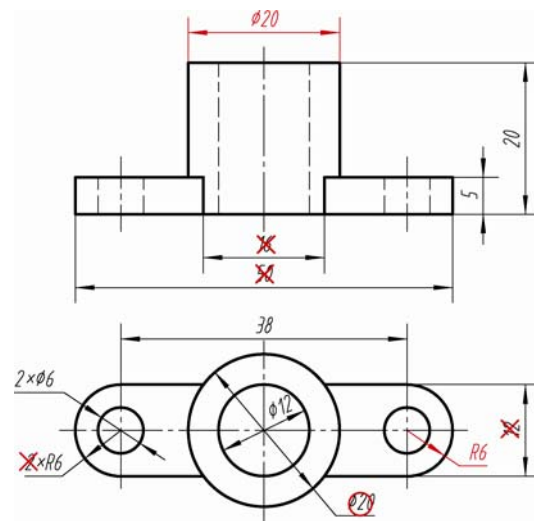

3-13-1

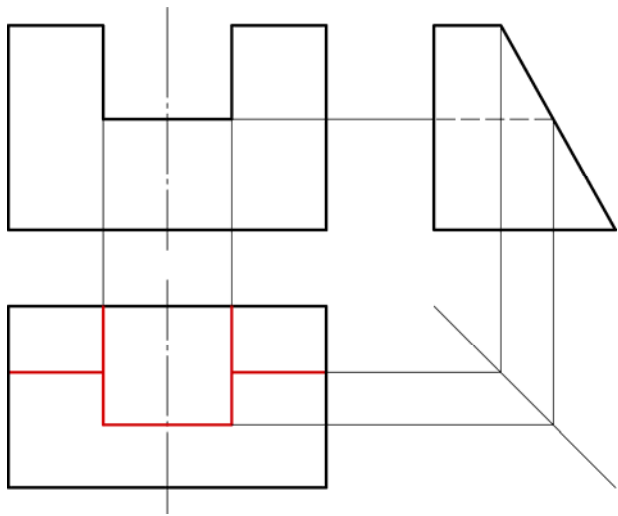

3-13-2

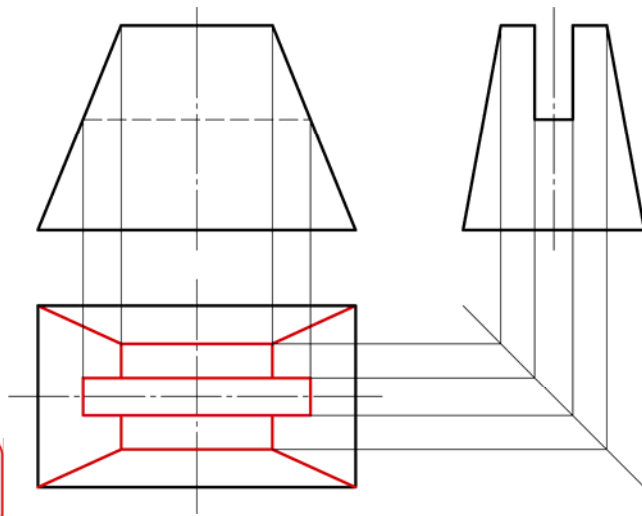

未经授权
禁止转载外传

3-13-3

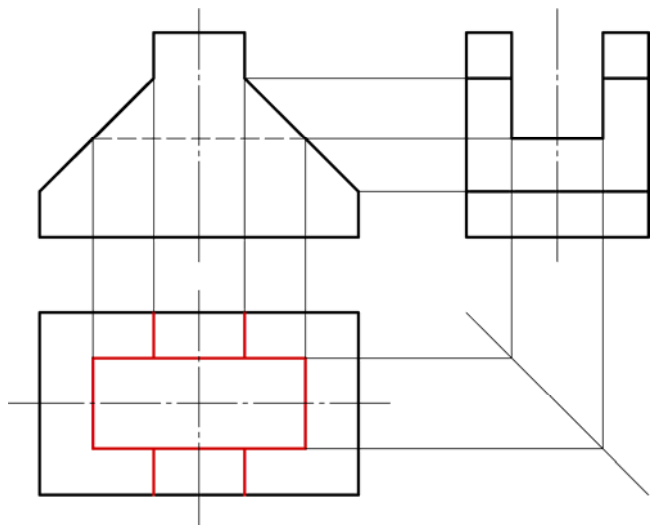

3-13-4

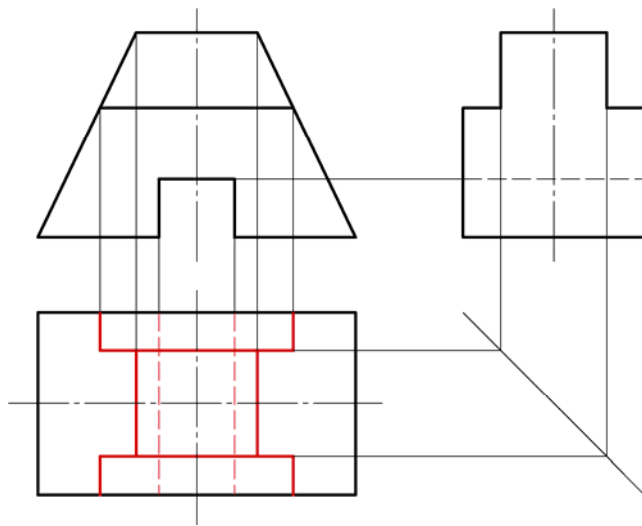

3-14-1 按 1:1 的比例画出三视图, 不注尺寸。

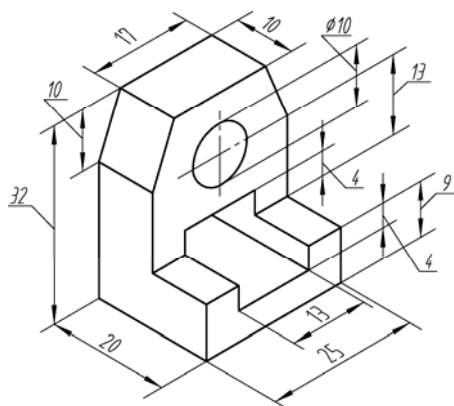
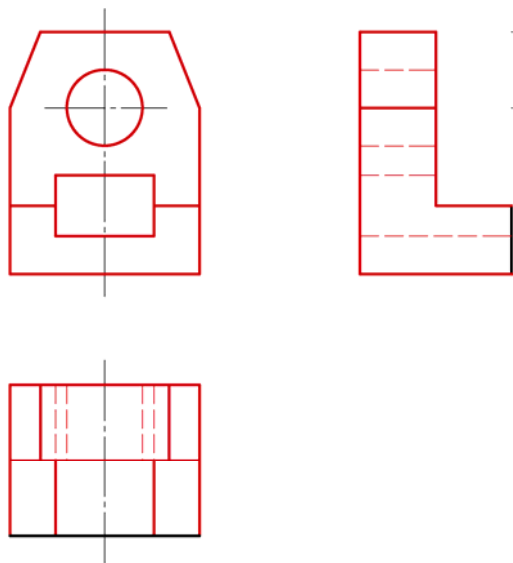

3-14-2 按 1:1 的比例画出三视图, 不注尺寸。

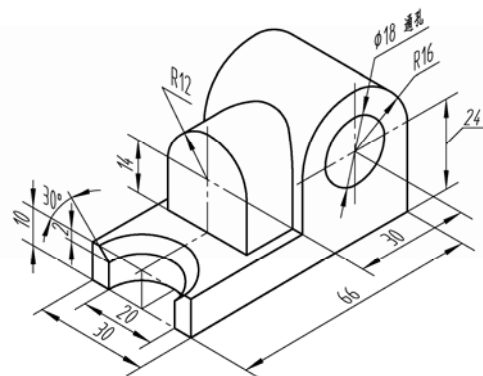
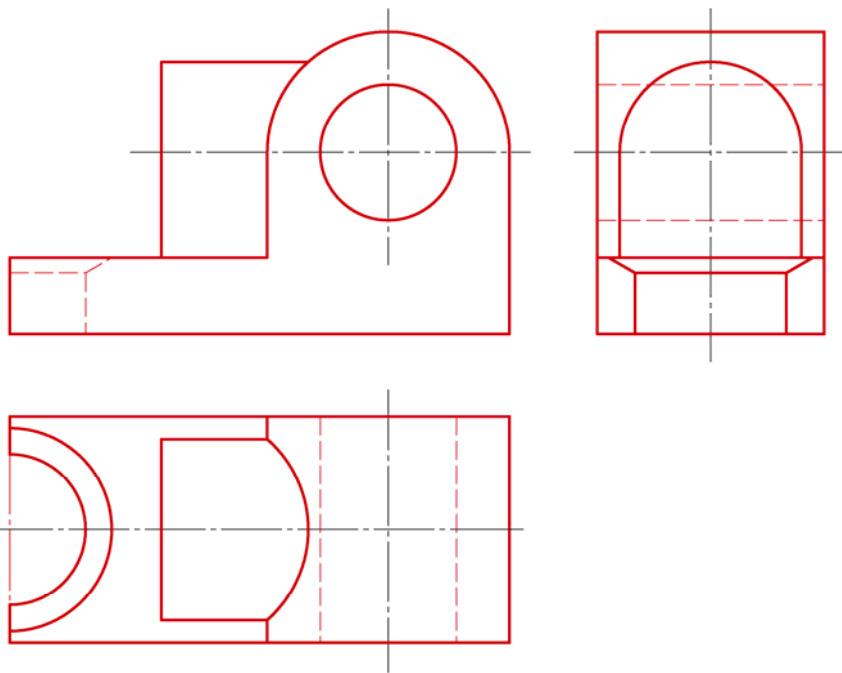

未经授权
禁止转载外传

以上内容仅为本文档的试下载部分，为可阅读页数的一半内容。如要下载或阅读全文，请访问：<https://d.book118.com/087013022032006161>