









# 制动控制线路的定义和作用



## 01

定义

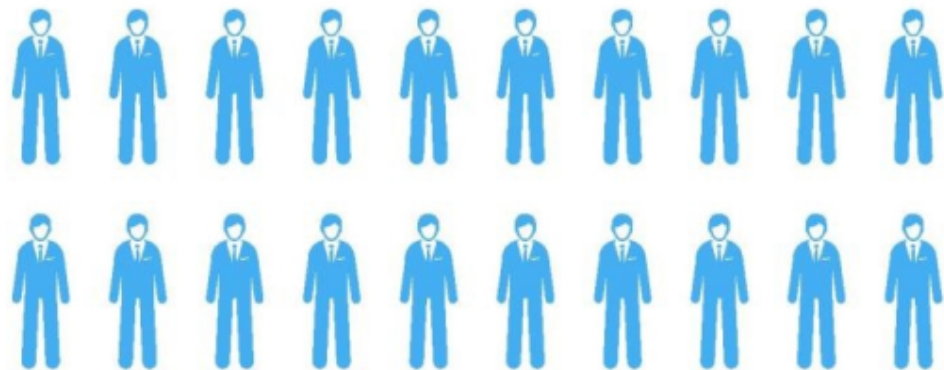

三相异步电动机的制动控制线路是指通过外部控制电路对电动机进行制动，使其迅速停止运转的控制线路。



## 02

作用

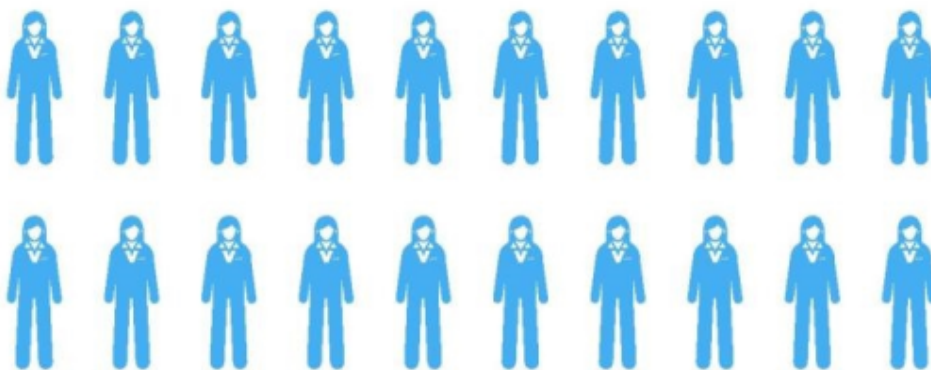

在某些需要快速停止电动机运转的场合，如机械臂定位、电梯停层等，制动控制线路起着至关重要的作用。



# 制动控制线路的分类

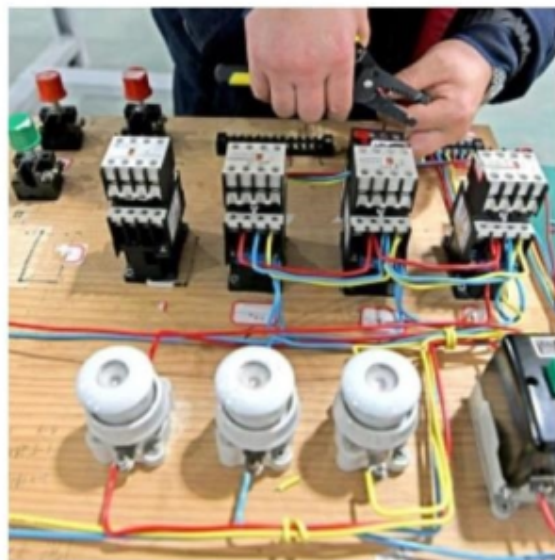

通过机械装置（如电磁铁、制动器等）对电动机进行制动。

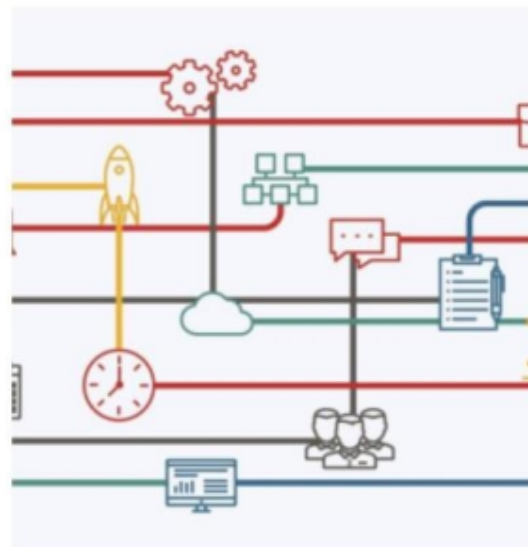

## 02

电气制动线路

## 01

机械制动线路

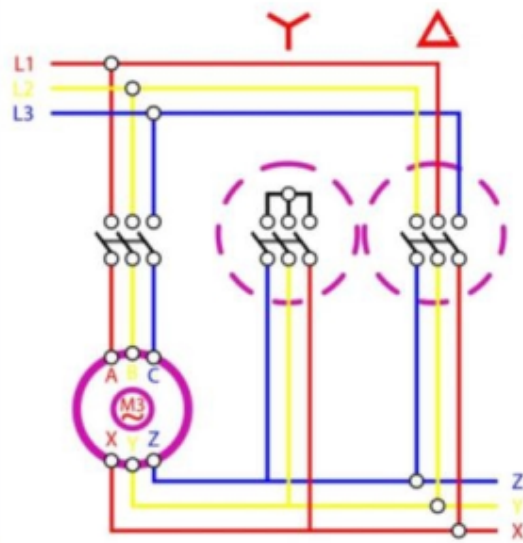

通过改变电动机的电源相序或频率等电气参数实现制动。

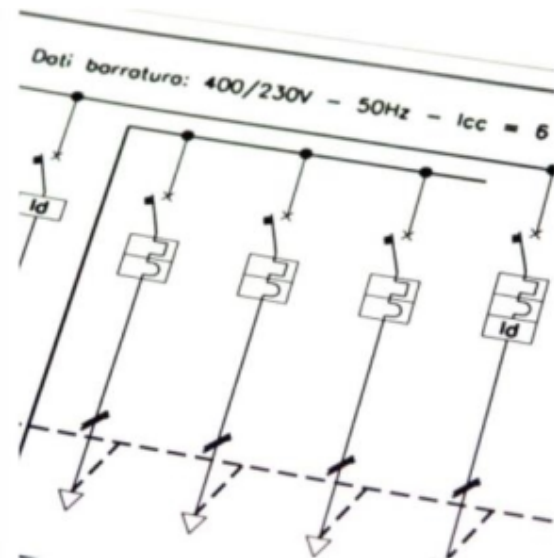





# 制动控制线路的工作原理

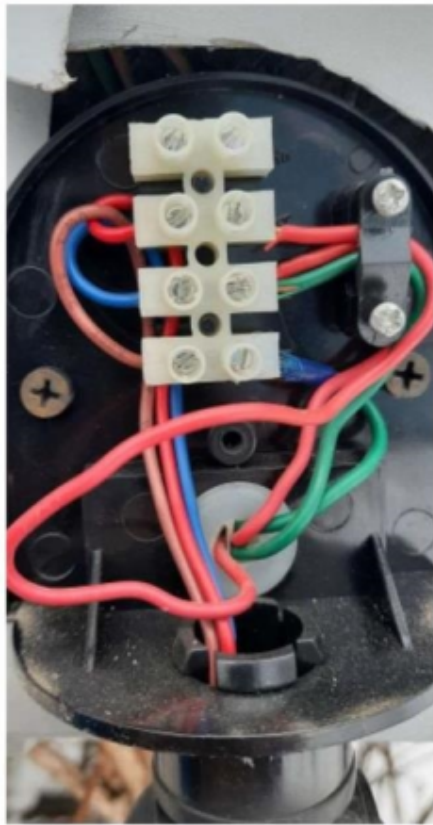
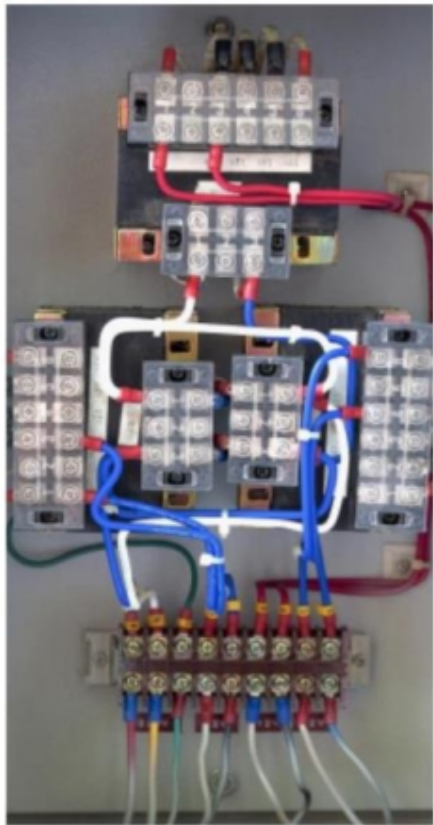

## 机械制动线路

当外部控制电路接通时，机械装置动作，对电动机进行制动，使其停止运转。



## 电气制动线路

当外部控制电路接通时，改变电动机电源的相序或频率，产生反向转矩或减缓转速，从而使电动机迅速停止运转。







# 能耗制动控制线路的组成



电源开关

用于控制整个控制线路的电源通断。



整流器

将交流电转换为直流电，为能耗制动提供直流电源。



制动电阻

在能耗制动过程中，将电动机的机械能转换为热能消耗掉。



控制器

根据控制逻辑，控制制动过程的启动和停止。



# 能耗制动控制线路的工作原理

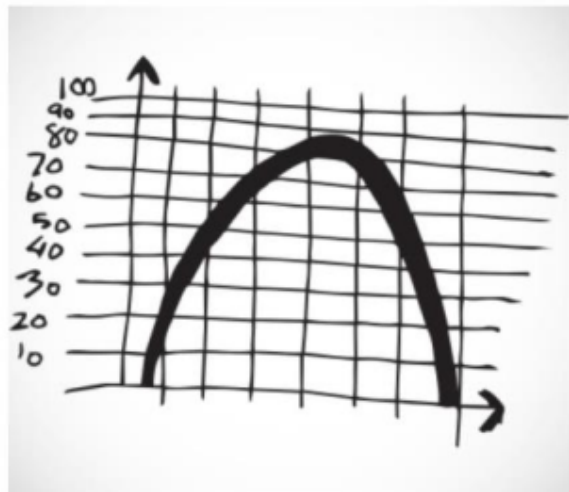
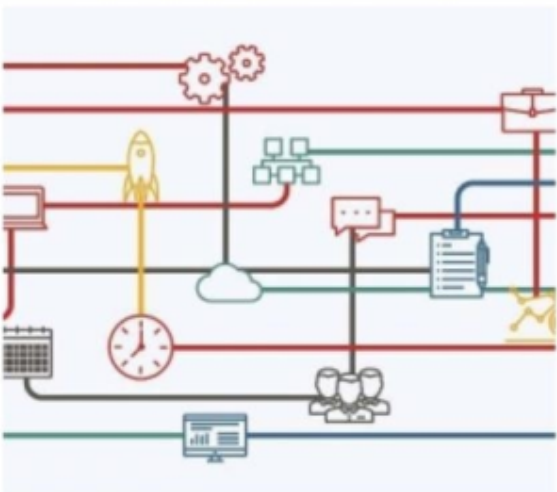

当三相异步电动机需要停车时，控制器会接通电源开关和整流器，使直流电源接入电动机的两相定子绕组。



电动机在直流电源的作用下产生一个反向的旋转磁场，从而产生反向的转矩使电动机迅速停车。



同时，制动电阻将电动机的机械能转换为热能消耗掉，实现能耗制动。



# 能耗制动控制线路的应用实例

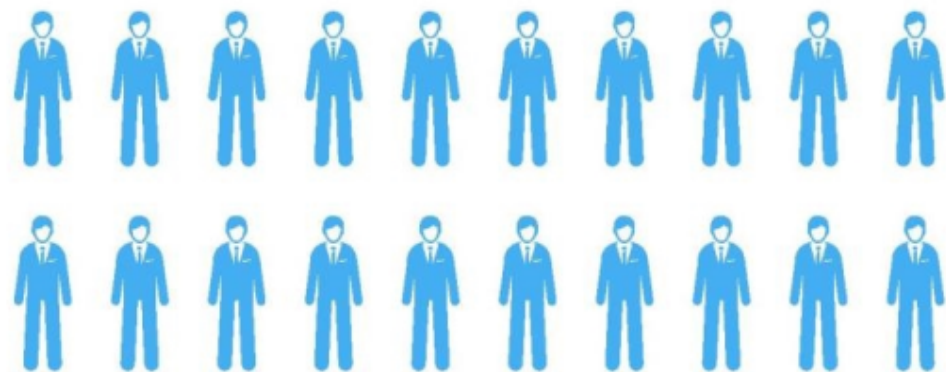
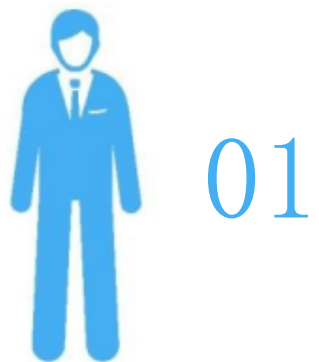

在电梯系统中，能耗制动控制线路常用于电梯的快速停车控制。

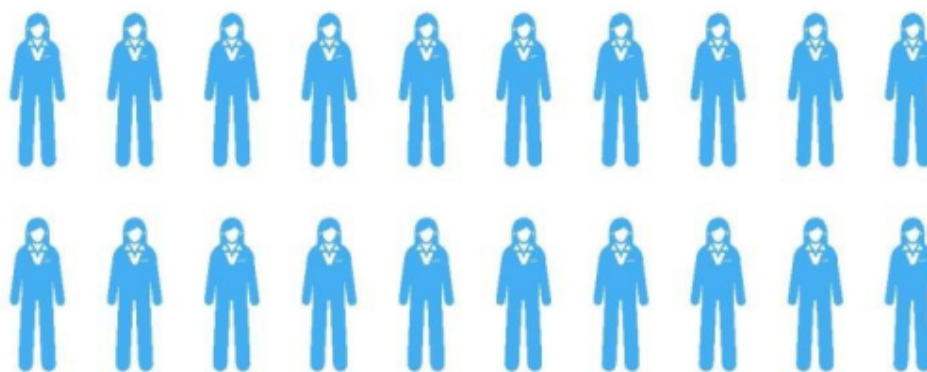
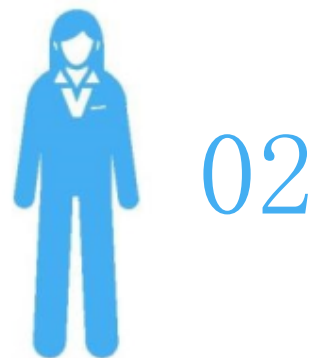

在包装机械中，能耗制动控制线路用于保证包装机械在快速停车时不会因为惯性而产生过大的冲击力。



以上内容仅为本文档的试下载部分，为可阅读页数的一半内容。如要下载或阅读全文，请访问：  
<https://d.book118.com/165244210044011212>