

镗削加工

《机械制造基础》





目录

CONTENTS

1 镗削工作内容

2 镗床

3 镗孔刀具

4 镗削加工方法





一、镗削工作内容

◆ 镗削加工范围

◆ 镗削特点及精度





镗削加工范围



图2-5-1 卧式镗床的工作内容及运动

- a)用主轴安装镗刀杆镗不大的孔
- b)用平旋盘上镗刀镗大直径孔
- c)用平旋盘上径向刀架进给镗平面
- d)主轴进给钻孔(小于80mm)
- e)用工作台进给镗螺纹
- f)用主轴进给镗螺纹
- g)主轴箱垂向进给铣平面
- h)双支承铣组合面
- i)利用后支承架支承镗杆(双支承)进行镗孔

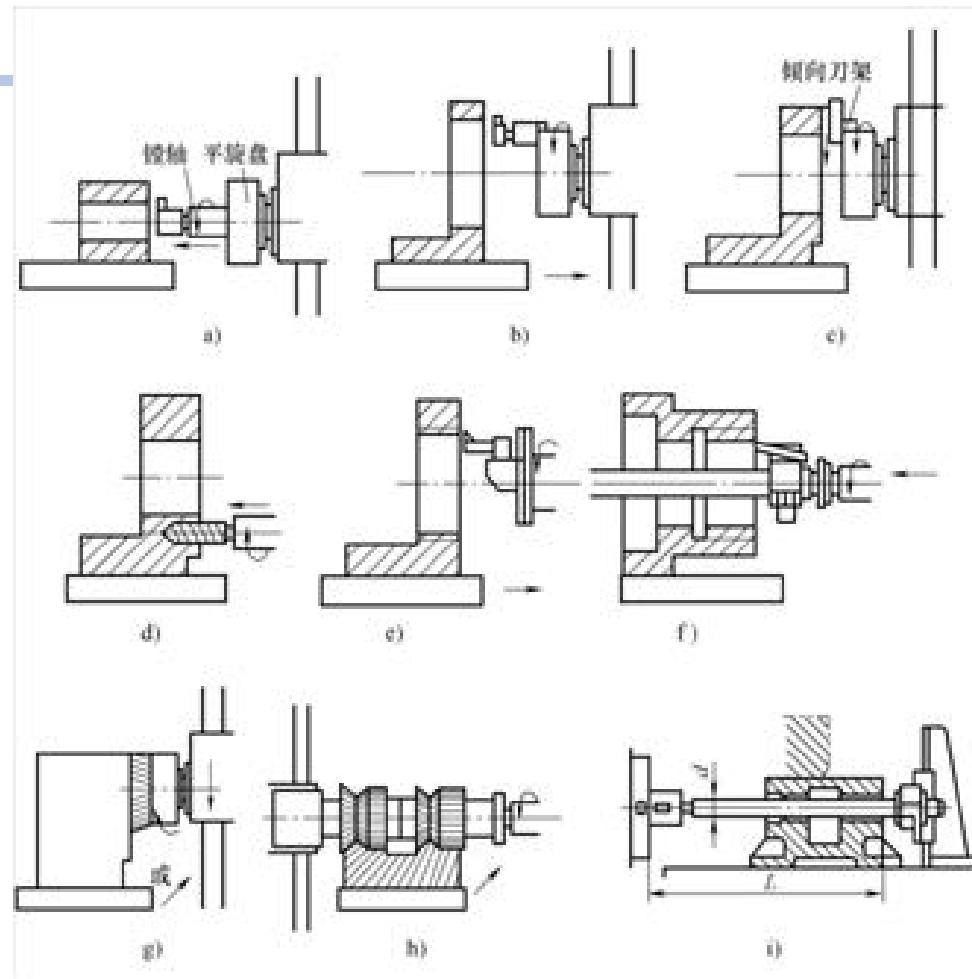

镗削特点及精度

除了在车床、钻床上加工孔以外，用镗孔刀具在镗床上也可以加工孔，与钻孔相比，镗床可以加工比较大的孔，精度较高。对于孔与孔之间较高的同轴度、垂直度、平行度及孔距精度等，镗孔是主要的切削加工方法。

镗削特别适合加工机座、箱体、支架等外形复杂的大型零件上的直径较大的孔以及有位置精度要求的孔和孔系，特别是有位置精度要求的孔和孔系。

镗削加工能获得较高的精度和较小的表面粗糙度值。加工零件一般尺寸公差等级为IT8、IT7，Ra值为1.6~0.8 μ m，孔距精度可达0.015mm。



二、镗床

- ◆ 卧式镗床外部结构
- ◆ 卧式镗床工作运动





卧式镗床外部结构



图2-5-2 卧式铣镗床的外形

- 1—后支架 2—后立柱 3—工作台 4—镗轴 5—平旋盘 6—径向刀具溜板
7—前立柱 8—主轴箱 9—后尾筒 10—床身 11—下滑座 12—上滑座



卧式镗床工作运动

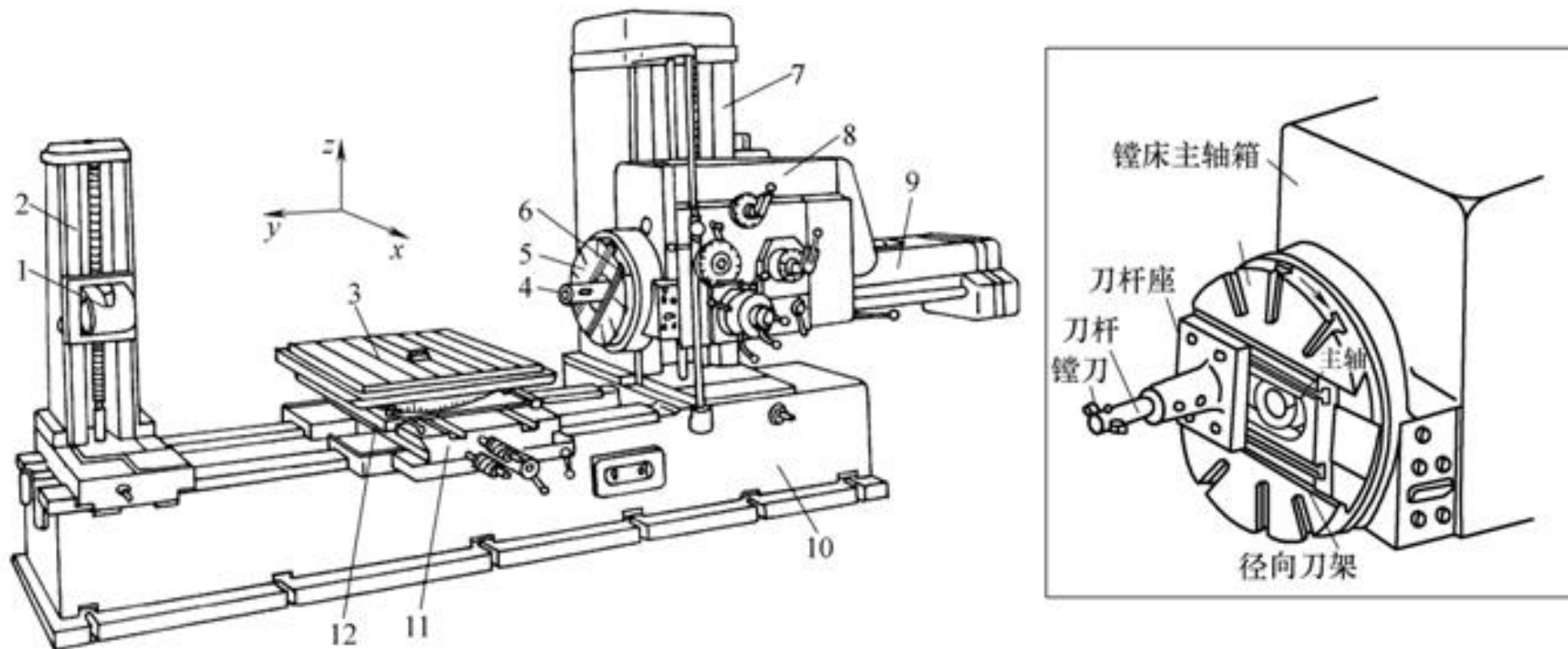

图2-5-3 卧式铣镗床的运动

a)镗小孔 b)双支承镗同轴孔 c)镗大孔 d)铣平面 e)车内沟槽 f)车端面

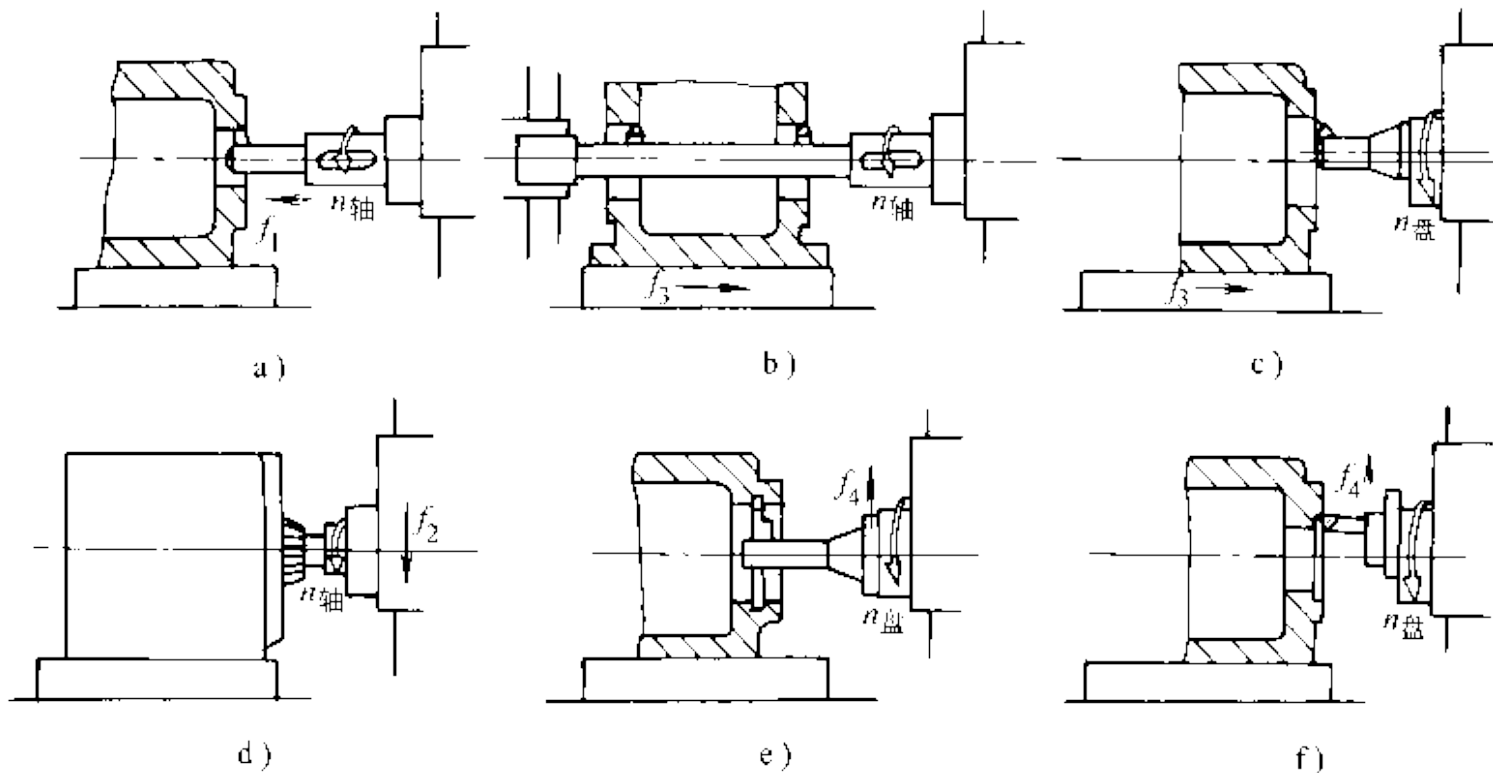

三、镗孔刀具

◆ 单刃镗刀

◆ 双刃镗刀





单刃镗刀



图2-5-4 单刃镗刀



双刃镗刀

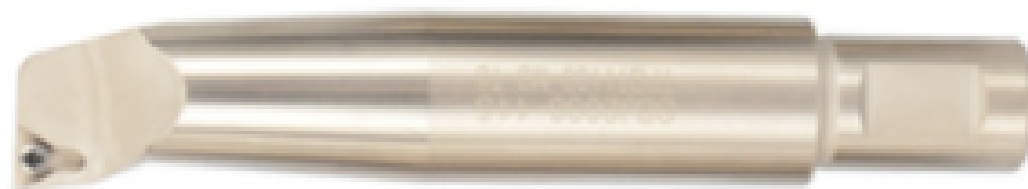

图2-5-5 双刃镗刀



四、镗削加工方法

◆ 工件安装

◆ 加工方法





工件安装



图2-5-6 工件在工作台上的安装位置



工件安装

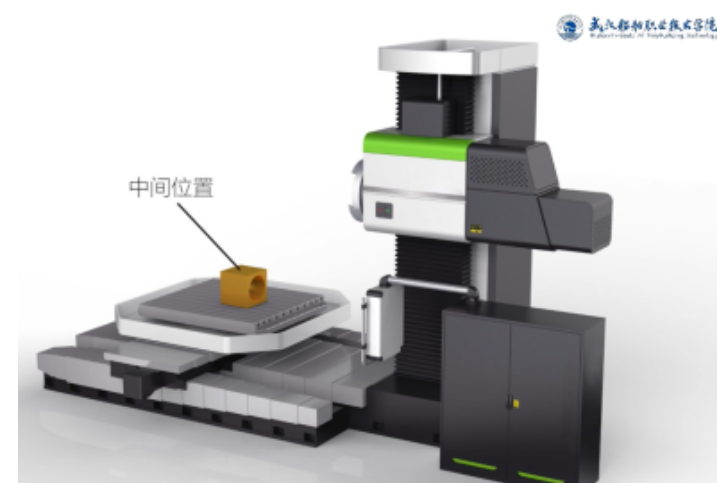
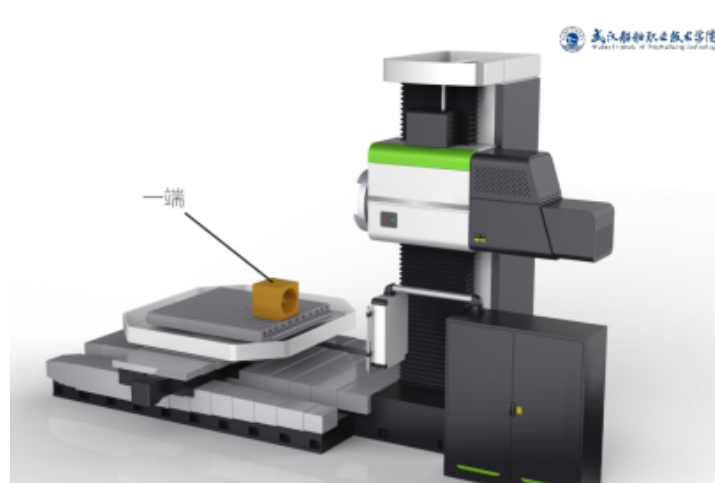
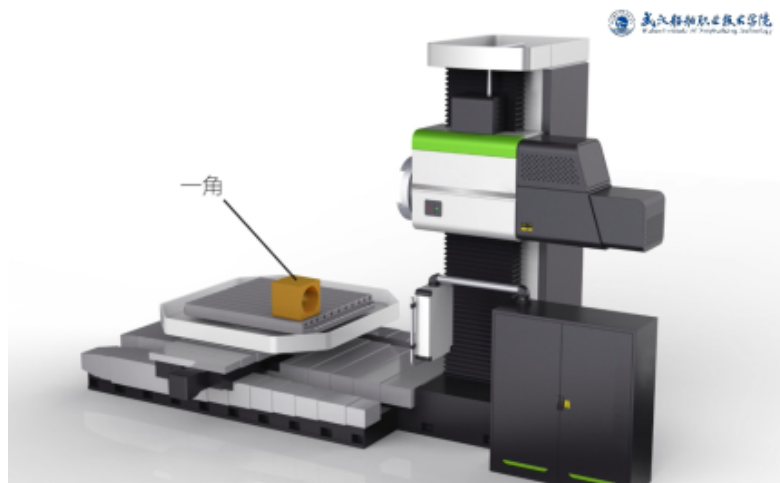
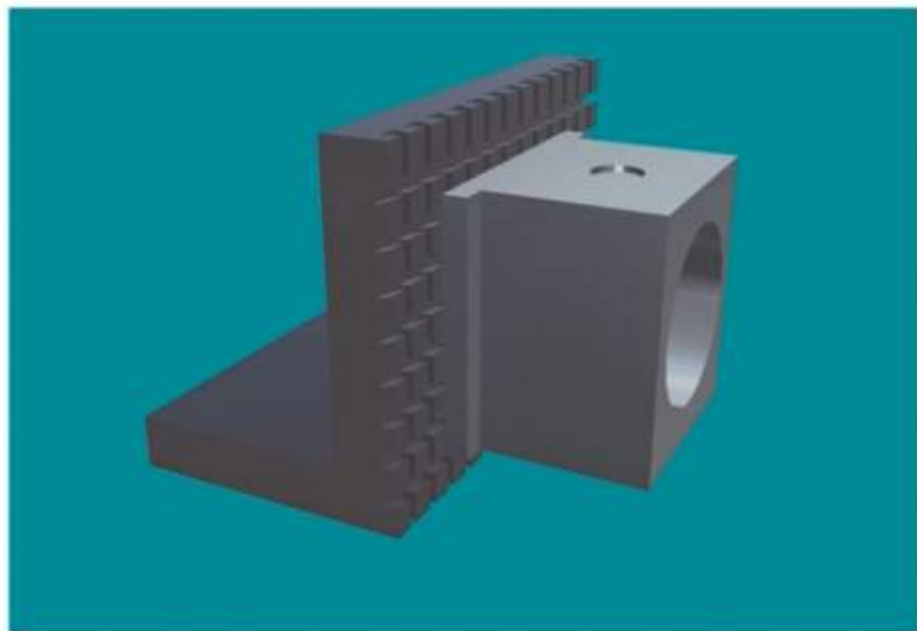

图2-5-7 底平面定位安装

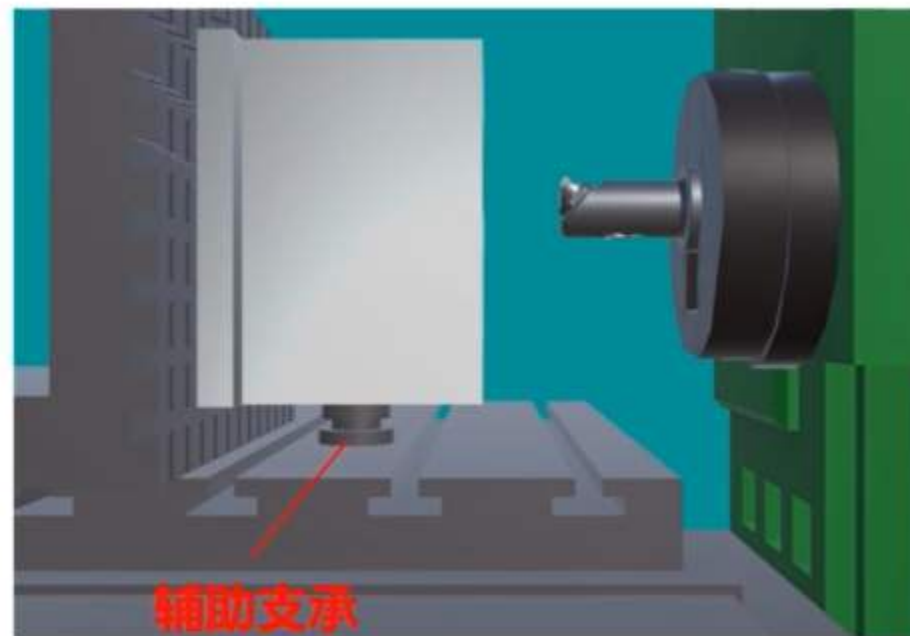

图2-5-8 侧平面加辅助支承安装

以上内容仅为本文档的试下载部分，为可阅读页数的一半内容。如要下载或阅读全文，请访问：
<https://d.book118.com/366224240242011013>