

MANUAL TRANSMISSION

GI

MA

EM

LC

EC

FE

CL

SECTION MT

CONTENTS

PREPARATION	2	DISASSEMBLY	20
Special Service Tools	2	INSPECTION	24
Commercial Service Tool	4	Shift Control Components	24
NOISE, VIBRATION AND HARSHNESS (NVH)		INSPECTION	24
TROUBLESHOOTING	5	Gear Components	24
NVH Troubleshooting Chart	5	INSPECTION	24
MANUAL TRANSMISSION	5	ASSEMBLY	26
ON-VEHICLE SERVICE	6	Gear Components	26
Replacing Rear Oil Seal - 2WD Model	6	ASSEMBLY	26
REMOVAL	6	Shift Control Components	34
INSTALLATION	6	ASSEMBLY	34
Position Switch Check - 2WD Model	6	Case Components	35
Position Switch Check - 4WD Model	7	ASSEMBLY	35
DESCRIPTION	8	SERVICE DATA AND SPECIFICATIONS (SDS)	37
Cross-sectional View - 2WD Model	8	General Specifications	37
Cross-sectional View - 4WD Model	9	Gear End Play	37
REMOVAL AND INSTALLATION	10	Clearance Between Baulk Ring and Gear	37
Removal	10	2ND AND 3RD BAULK RING	38
2WD MODEL	10	Distance Between Rear Surface of Reverse	
4WD MODEL	11	Cone and Reverse Baulk Ring	38
Installation	12	Available Snap Ring	38
OVERHAUL	14	MAIN DRIVE GEAR SNAP RING	38
Case Components	14	MAINSHAFT FRONT SNAP RING	38
Gear Components	15	COUNTER GEAR REAR SNAP RING	39
Shift Control Components	17	Available C-ring	39
DISASSEMBLY	18	MAINSHAFT C-RING	39
Case Components	18	Available Shim and Washer	40
DISASSEMBLY	18	TABLE FOR SELECTING PROPER COUNTER	
Shift Control Components	19	GEAR FRONT BEARING THRUST WASHER	40
DISASSEMBLY	19	REVERSE IDLER REAR THRUST WASHER	40
Gear Components	20		

MT

AT

TF

PD

AX

SU

BR

ST

RS

BT

HA

SC

EL

IDX

PREPARATION

Special Service Tools

Special Service Tools

NAMT0001

The actual shapes of Kent-Moore tools may differ from those of special service tools illustrated here.

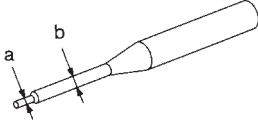
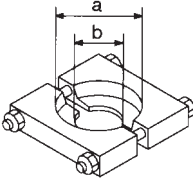
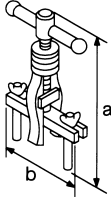
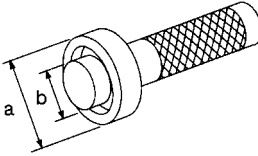
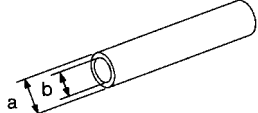
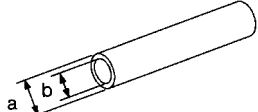
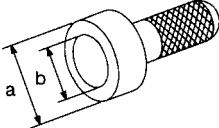
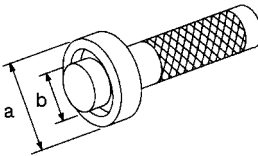
Tool number (Kent-Moore No.) Tool name	Description	
ST23540000 (J25689-A) Pin punch		Removing and installing retaining pin a: 2.3 mm (0.091 in) dia. b: 4 mm (0.16 in) dia.
NT442		
ST30031000 (J22912-01) Puller		Removing 1st & 2nd synchronizer assembly Removing counter gear rear thrust bearing Removing main drive bearing a: 90 mm (3.54 in) dia. b: 50 mm (1.97 in) dia.
NT411		
ST33290001 (J25810-A) Puller		Removing rear oil seal a: 250 mm (9.84 in) b: 160 mm (6.30 in)
NT414		
ST33230000 (—) Drift		Removing mainshaft and counter gear a: 51 mm (2.01 in) dia. b: 28.5 mm (1.122 in) dia.
NT084		
ST22350000 (J25678-01) Drift		Removing counter gear front bearing (Use with KV38100300) a: 34 mm (1.34 in) dia. b: 28 mm (1.10 in) dia.
NT065		
KV38100300 (J25523) Drift		Removing counter gear front bearing (Use with ST22350000) Installing counter gear rear bearing a: 54 mm (2.13 in) dia. b: 32 mm (1.26 in) dia.
NT065		
ST30720000 1 (J34286) 2 (J34331) Drift		1 Removing mainshaft front bearing 2 Installing mainshaft front bearing a: 77 mm (3.03 in) dia. b: 55.5 mm (2.185 in) dia.
NT115		
ST33210000 1 (J25523) 2 (J25803-01) Drift		1 Installing counter gear front bearing 2 Installing front cover oil seal a: 44 mm (1.73 in) dia. b: 24.5 mm (0.965 in) dia.
NT084		

PREPARATION

Special Service Tools (Cont'd)

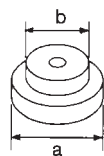
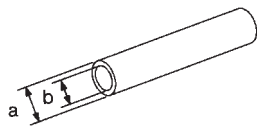
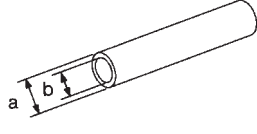
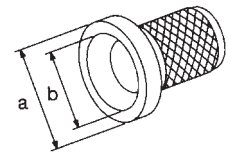
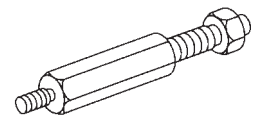
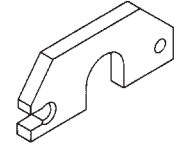
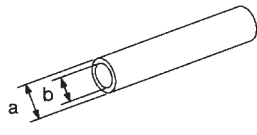
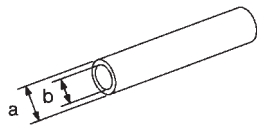
Tool number (Kent-Moore No.) Tool name	Description	
ST30613000 (J25742-3) Drift		Installing main drive gear bearing a: 72 mm (2.83 in) dia. b: 48 mm (1.89 in) dia.
	NT073	
ST37750000 1 (J34286) 2 (J34332) 3 (J34334) 4 (J25679-01) Drift		1 Removing counter gear rear bearing 2 Installing OD gear bushing 2 Removing and installing mainshaft rear bearing (4WD model) 2 Installing reverse cone 3 Installing reverse counter gear 4 Installing counter gear rear end bearing a: 40 mm (1.57 in) dia. b: 31 mm (1.22 in) dia.
	NT065	
ST22452000 (J34337) Drift		Installing reverse hub Installing mainshaft rear bearing (2WD model) a: 45 mm (1.77 in) dia. b: 36 mm (1.42 in) dia.
	NT065	
ST33400001 (J26082) Drift		Installing rear oil seal a: 60 mm (2.36 in) dia. b: 47 mm (1.85 in) dia.
	NT086	
(J26349-3) Puller leg		Installing mainshaft and counter gear (Use with J34328)
	NT078	
(J34328) Puller		Installing mainshaft and counter gear (Use with J26349-3)
	NT079	
(J26092) Drift		Installing sub-gear snap ring a: 44.5 mm (1.752 in) dia. b: 38.5 mm (1.516 in) dia.
	NT065	
(J34342) Drift		Installing OD main gear Installing reverse gear bushing a: 44.5 mm (1.752 in) dia. b: 40.5 mm (1.594 in) dia.
	NT065	

PREPARATION

Special Service Tools (Cont'd)

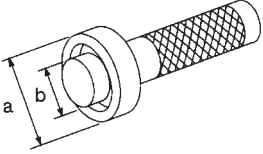
Tool number (Kent-Moore No.) Tool name	Description	
ST33220000 (J25804-01) Drift		Installing mainshaft rear bearing a: 37 mm (1.46 in) dia. b: 22 mm (0.87 in) dia.
	NT084	

Commercial Service Tool

NAMT0002

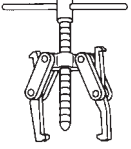
Tool name	Description	
Puller		Removing counter gear rear end bearing Removing mainshaft rear bearing (2WD model) Removing reverse synchronizer hub Removing reverse counter gear
	NT077	

NOISE, VIBRATION AND HARSHNESS (NVH) TROUBLESHOOTING

NAMT0023

NVH Troubleshooting Chart

NVH Troubleshooting Chart

NAMT0023S01

Use the chart below to help you find the cause of the problem. The numbers indicate the order of the inspection. If necessary, repair or replace these parts.

MANUAL TRANSMISSION

NAMT0023S0101

Reference page		Refer to MA-22, "Checking M/T Oil".											
SUSPECTED PARTS (Possible cause)		OIL (Level low)	OIL (Wrong)	OIL (Level too high)	GASKET (Damaged)	OIL SEAL (Worn or damaged)	O-RING (Worn or damaged)	CHECK PLUG RETURN SPRING AND CHECK BALL (Worn or damaged)	SHIFT FORK (Worn)	GEAR (Worn or damaged)	BEARING (Worn or damaged)	BAULK RING (Worn or damaged)	INSERT SPRING (Damaged)
		Symptom	Noise	1	2							3	3
Oil leakage			3	1	2	2	2						
Hard to shift or will not shift			1	1								2	2
Jumps out of gear								1	2	2			

GI
MA
EM
LC
EC
FE
CL
MT
AT
TF
PD
AX
SU
BR
ST
RS
BT
HA
SC
EL
IDX

ON-VEHICLE SERVICE

Replacing Rear Oil Seal — 2WD Model

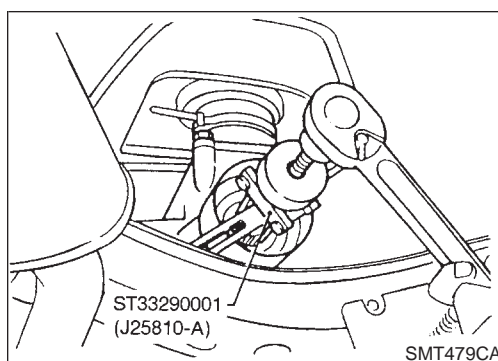

Replacing Rear Oil Seal — 2WD Model REMOVAL

NAMT0003

NAMT0003S01

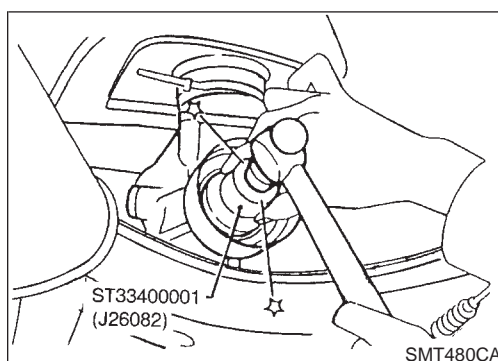

INSTALLATION

NAMT0003S02

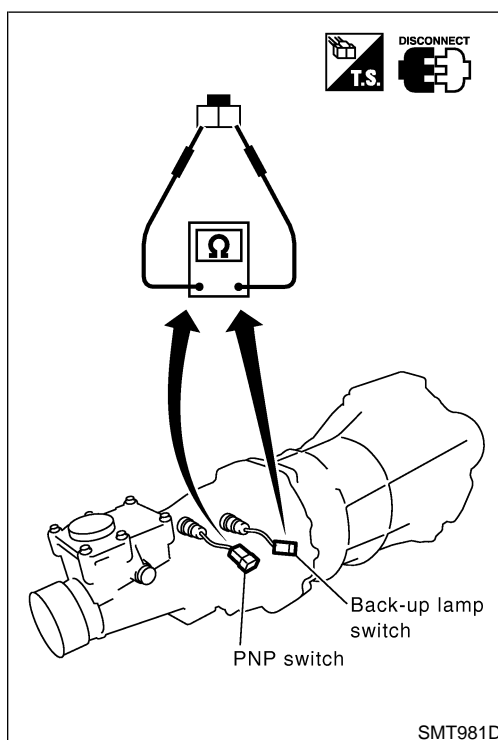

Position Switch Check — 2WD Model

NAMT0004

Switch	Gear position	Continuity
Back-up lamp switch	Reverse	Yes
	Except reverse	No
PNP switch	Neutral	Yes
	Except neutral	No

ON-VEHICLE SERVICE

Position Switch Check — 4WD Model

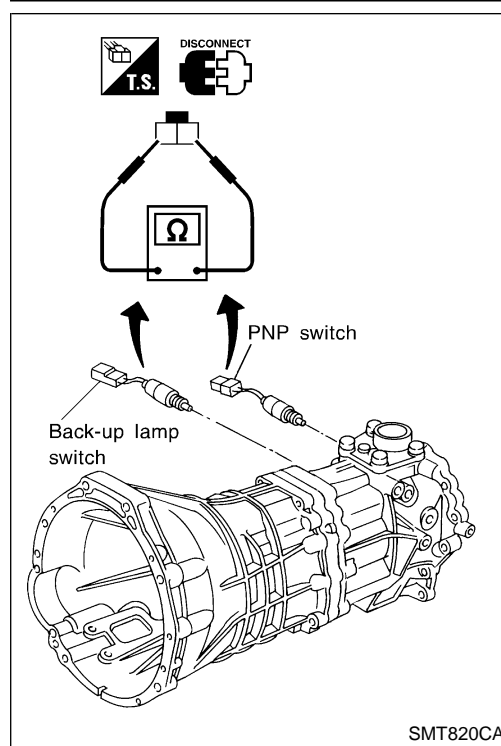

Position Switch Check — 4WD Model

NAMT0024

Switch	Gear position	Continuity
Back-up lamp switch	Reverse	Yes
	Except reverse	No
PNP switch	Neutral	Yes
	Except neutral	No

GI

MA

EM

LC

EC

FE

CL

MT

AT

TF

PD

AX

SU

BR

ST

RS

BT

HA

SC

EL

IDX

以上内容仅为本文档的试下载部分，为可阅读页数的一半内容。如要下载或阅读全文，请访问：<https://d.book118.com/438032073036006064>