

- 1-2. Lift up Top Cover and unplug two wires connected to IR PWB Unit and Main Unit. (Refer to Step 3~5.)
- 1-3. Remove Top Cover.
- 1-4. Remove one screw to take off IR PWB Unit and IR PWB Unit Cover.
- 1-5. Remove four D-SUB shafts from the D-SUB Terminals to take off Terminal Sheet. (Refer to Step 6~7.)



Step 3

1-2



Step 4

1-2

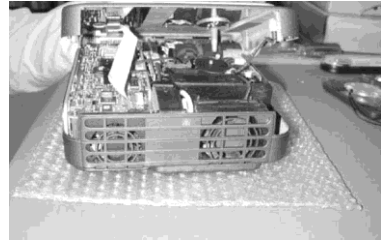

Step 5

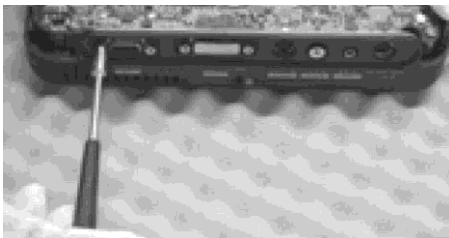
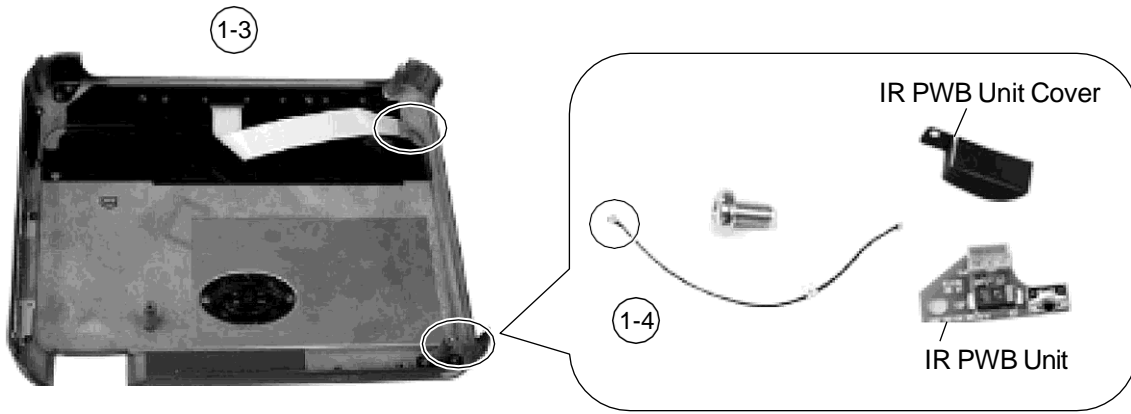

Step 6

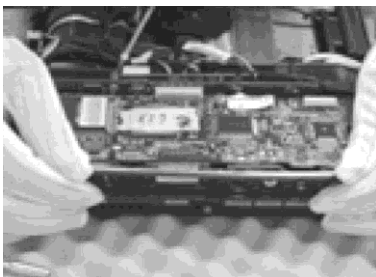
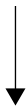

Step 7

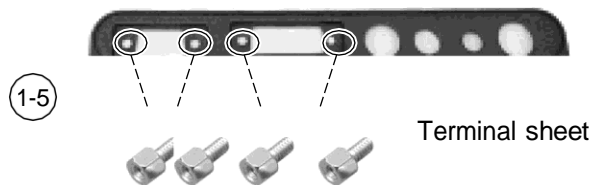
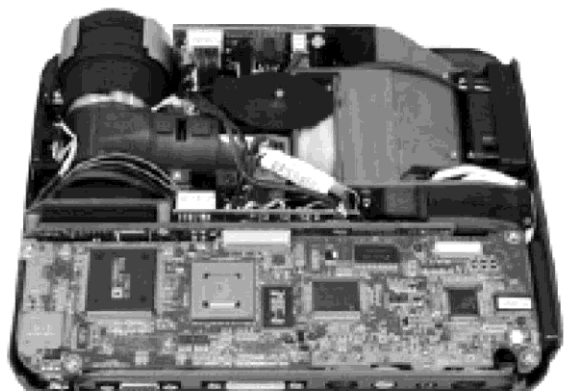

## 2. Disassemble Optical Engine Module

- 2-1. Remove 4 screws from main PWB unit.
- 2-2. Using a ball end hexagonal driver, loosen 2 screws holding terminal sheet holder. (approx. 4 rotation)(Step 8.)
- 2-3. Place a tool in between main PWB unit and formatter PWB unit and disconnect the connector. (Step 9.)
- 2-4. Pull the main unit outwards and remove main PWB unit. (Step 10,11.)

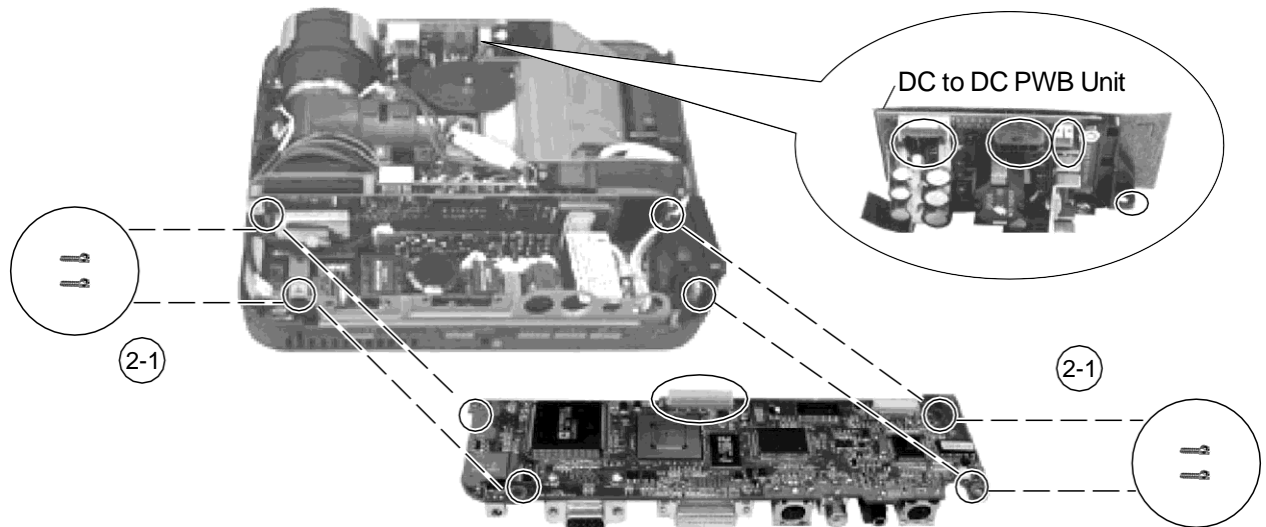

2-2



Step 8

2-3

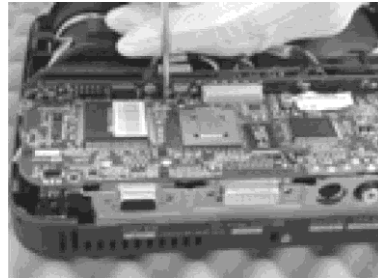

Step 9

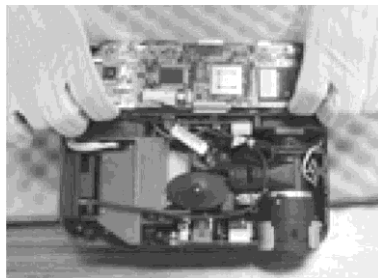

Step 10

2-4



Step 11

2-5. Remove one screw of DC to DC PWB Unit Holder, unplug three Connecting Cords, and then detach DC to DC PWB Unit.  
(Step 12,13.)

(Step 12,13.)

2-6. Remove push bar, push bar spring, and rubber. (refer to step 14~16.)

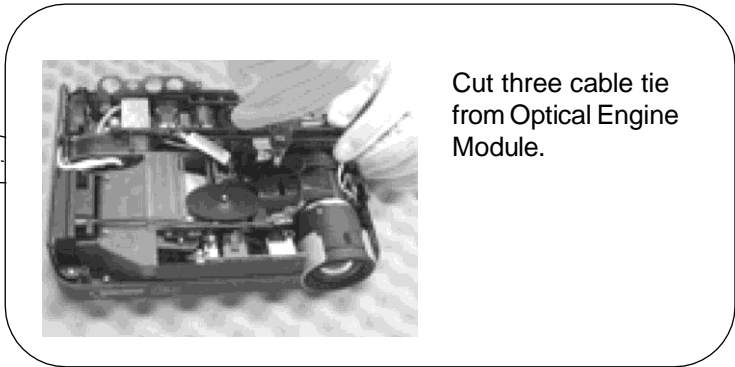
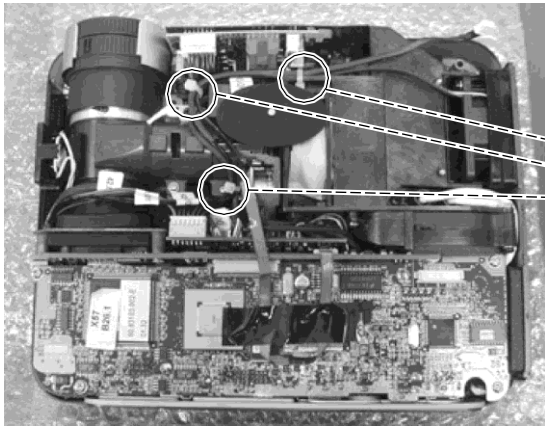

Step 12

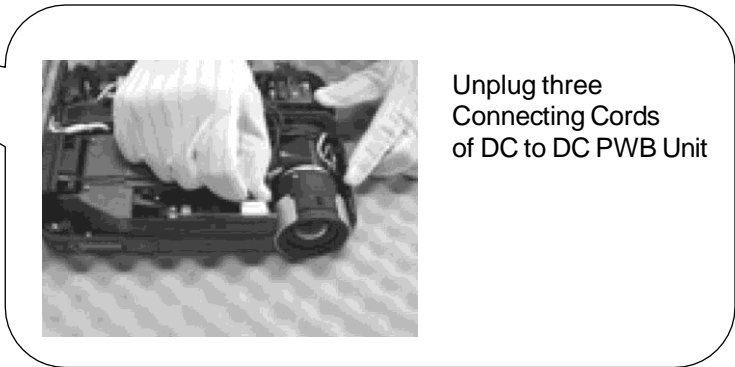
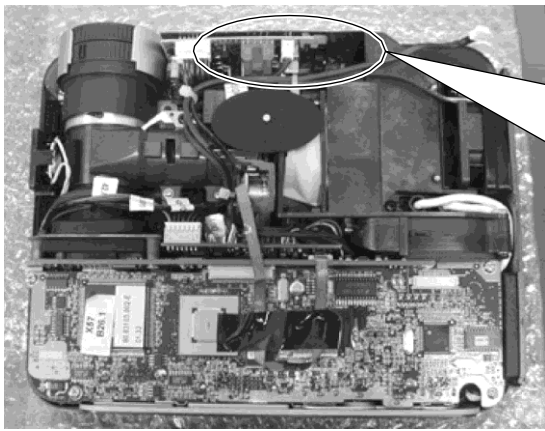
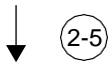

Step 13

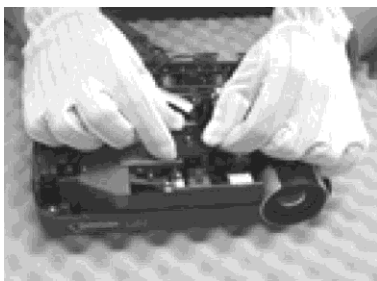

Step 14

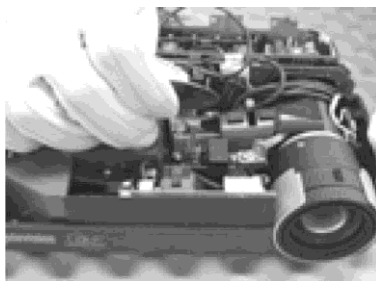

Step 15

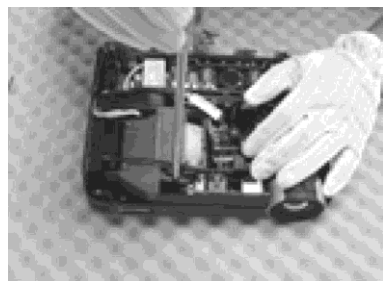

Step 16

- 2-7. Unplug six wires of Thermal PWB Unit. (Step 17.)
- 2-8. Remove 5 screws from optical engine module (Step 18~20.)
- 2-9. Remove 2 screws from projection lens cover. (Step 21.)
- 2-10. Remove optical engine module, projection lens cover, and Thermal Unit. (Step 22, 23.)

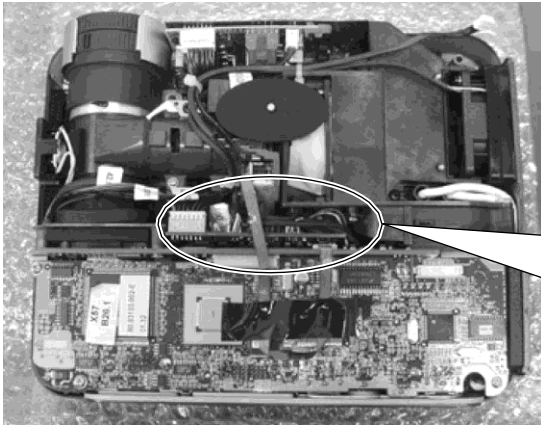

Step 17

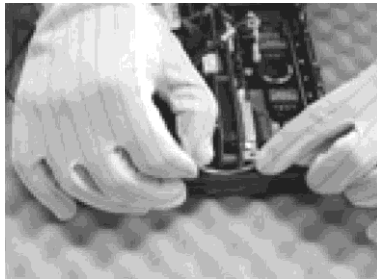
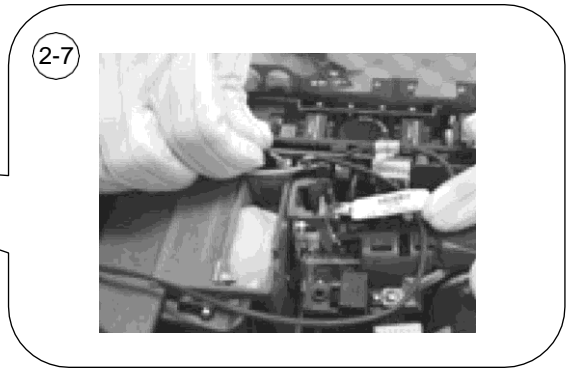

Step 18

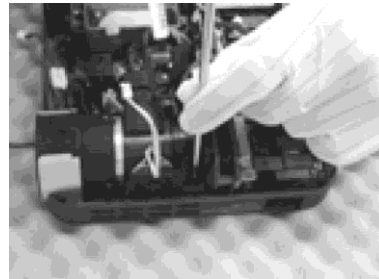

Step 19



Step 20



Step 21

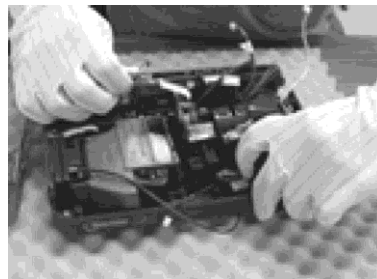

Step 22

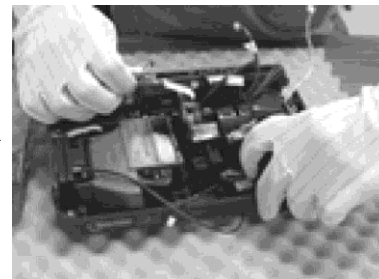

Step 23

以上内容仅为本文档的试下载部分，为可阅读页数的一半内容。如要下载或阅读全文，请访问：<https://d.book118.com/448035105031006032>