

板式橡胶支座

一、公路桥梁板式橡胶支座规格系列

1、范围

本标准规定了板式橡胶支座的要求、规格系列及选用。

本标准适用于承载力小于 5000kN 的公路桥梁用矩形、圆形平板式橡胶支座。

2、规范性引用文件

下列文中的条款通过本标准的引用而成为本标准的条款。凡是注日期的引用文件，其随后所有的修改（不包括勘误的内容）或修订版均不适用于本标准，然而，鼓励根据本标准达成协议的各方研究是否可使用这些文件的最新版本。凡是不注日期的引用文件，其最新版本适用于本标准。

JT/T4 — 2004 公路桥梁板式橡胶支座

JTG D60 — 2004 公路桥涵设计通用规范

JTG D62 — 2004 公路钢筋混凝土及预应力混凝土桥涵设计规范

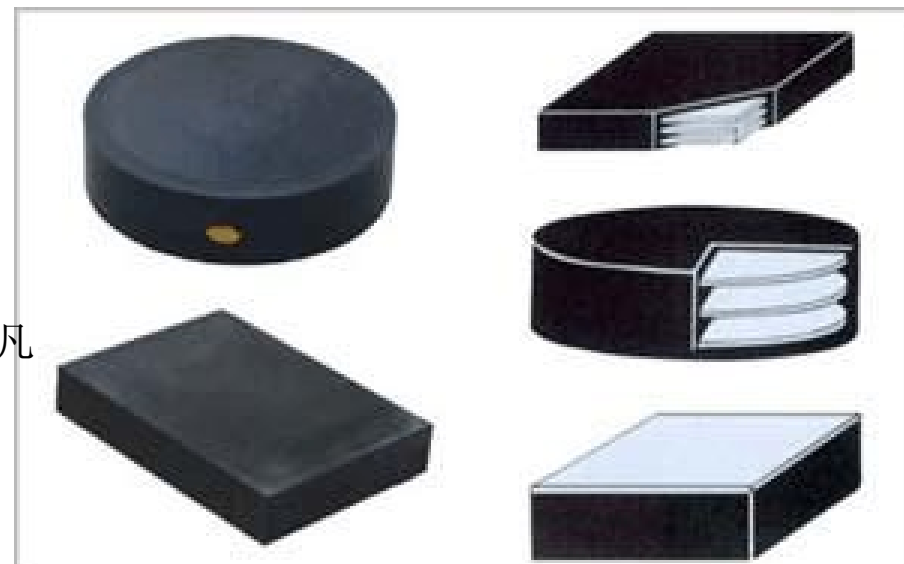

3、支座要求

3.1 支座产品分类、代号、结构、技术要求、试验方法、检验规则及标志、包装、贮存、运输、安装和养护均应满足JT/T4 — 2004 的要求。

3.2 支座使用阶段平均压应力 $6C=10\text{MPa}$ ($S < 7$ 时 $6C=8\text{MPa}$)；橡胶硬度 60 (IRHD) 时，其常温下剪变模量 $G=1.0\text{MPa}$ 。剪变模量随温度下降而递增，

当累年最冷月平均温度的平均值 $0 \sim -10^\circ\text{C}$ 时为寒冷地区， $G=1.2\text{MPa}$ ；当低于 -10°C 时为严寒地区， $G=1.5\text{MPa}$ ；当低于 -25°C 时， $G=2.0\text{MPa}$ 。全国气温分区图见 JTG D60 — 2004 附录 B。

3.3 支座橡胶弹性体体积模量 $E_b=2000\text{MPa}$ 。支座与混凝土接触时，摩擦系数 $\mu=0.3$ ，与钢板接触时，摩擦系数 $\mu=0.2$ 。聚四氟乙烯板与不锈钢板接触（加硅脂）时， $\mu_f=0.06$ ，当温度低于 -25°C 时， μ_f 值增大 30%，当不加硅脂时， μ_f 应加倍。若有实测资料时，也可按实测资料采用。

3.4 橡胶支座剪切角 α 正切值，当不计制动力时， $\tan \alpha$ 不大于 0.5，当计入制动力时， $\tan \alpha$ 不大于 0.7。

3.5 橡胶支座的计算和验算均应满足 JTG D62 — 2004 的要求。

4、普通板式橡胶支座

4.1 普通板式橡胶支座结构示意图见图 1、图 2。

4.2 普通板式橡胶支座代号，矩形为GJZ、圆形为GYZ。其规格系列见表 1，表中符号意义如下：

$a \times b$ 或 d -----平面尺寸或直径；

R_{ck} -----最大承压力；

S -----形状系数；

t -----支座总厚度；

Δl_1 , -----不计制动力时最大位移量；

Δl_2 -----计人制动力时最大位移量；

t_e -----橡胶层总厚度；

$\tan\theta$ -----允许转角正切值；

R_{Gk} -----抗滑最小承压力；

板式橡胶支座产品代号表示方法

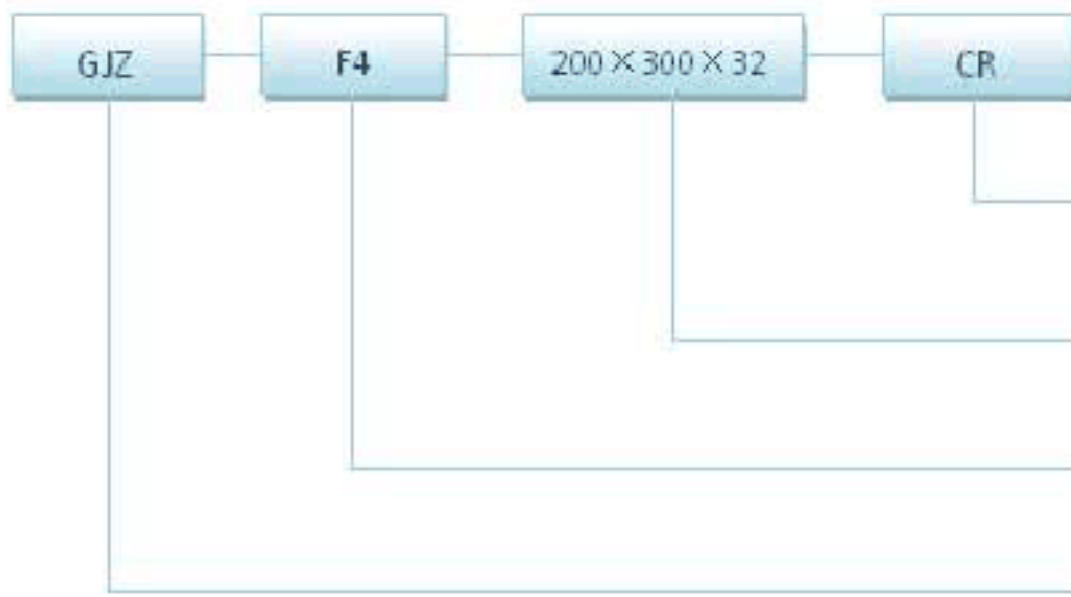

橡胶种类：天然橡胶 CR、氯丁橡胶 NR、三元乙丙橡胶 EPDM

外形尺寸（矩形 $L_a \times L_b \times t$ (mm) 圆形 $d \times t$ (mm)）

形式代号（F4 表示四氟滑板支座；无代号为普通支座）

名称代号：GJZ 表示公路桥梁矩形支座；

GYZ 表示公路桥梁圆形支座；

TBZ 表示铁路桥梁板式支座；

TCYB 表示公路球冠式支座。

t_1 —— 中间橡胶层厚度。
 t_2 —— 单层钢板厚度。



图1 矩形板式橡胶支座结构示意图（尺寸单位：mm）
 1— 加劲钢板；2— 橡胶层



图2 圆形板式橡胶支座结构示意图（尺寸单位：mm）
 1— 加劲钢板；2— 橡胶层

GJZ、GYZ 板式橡胶支座规格系列选用参数

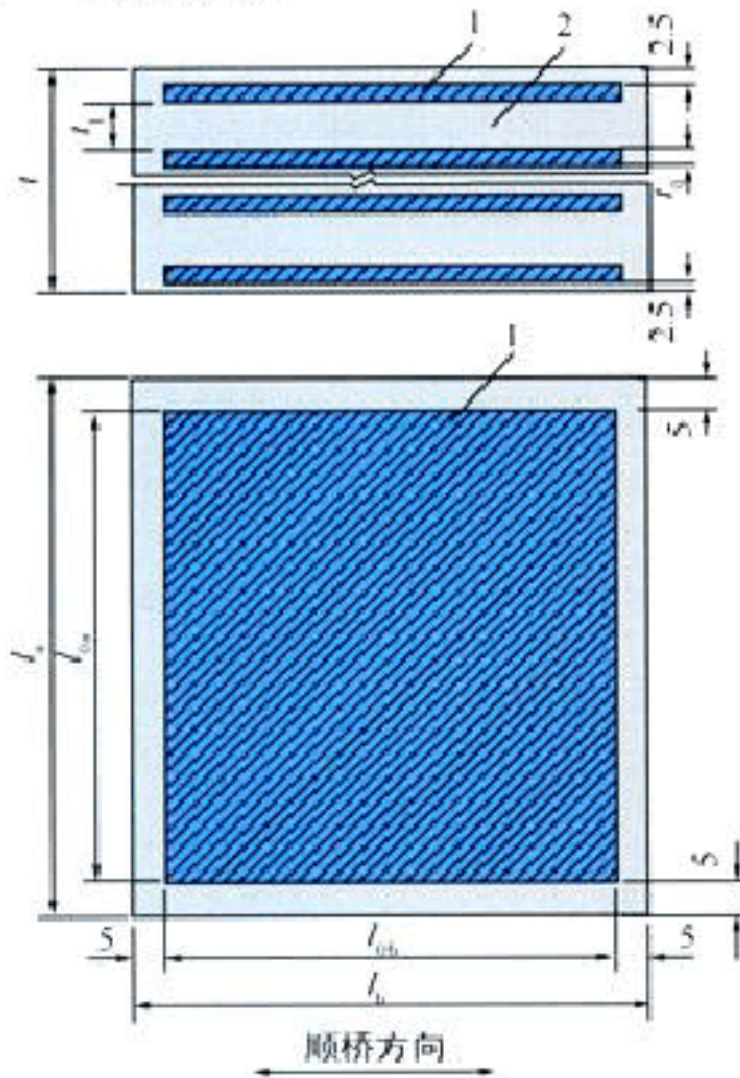
序号	l _a ×l (或 d) (mm)	R (KN)	S	t(mm)	Δl ₁	Δl ₂	t _e	tanθ (θ 的单位为rad)			R _{CK} (KN)			t ₁ (mm)	t ₀ (mm)
								温热地区	寒冷地区	严寒地区	温热地区	寒冷地区	严寒地区		
1	GJZ 100×150	101	5.48	21	5	7	15	0.010 7	0.009	0.007 4	35(53)	42(63)	53(79)	5	2
				28	7.5	10.5	20	0.016	5	0.013 1					
2	GJZ 100×200	137	6.11	21	5	7	15	0.008 7	0.007 4	0.006 1	47(70)	56(84)	70(105)	5	2
				28	7.5	10.5	20	0.013 1	0.011 1	0.009 1					
3	GYZ d150	154	7	21	5	7	15	0.005 7	0.005	-	41(62)	49(74)	62(93)	5	2
				28	7.5	10.5	20	0.008 5	0.007 3	0.006					
				35	10	14	25	0.011 4	0.009 7	0.008					
				42	12.5	17.5	30	0.014 3	0.012 2	0.010 1					
4	GJZ 150×150	196	7	21	5	7	15	0.005 7	0.005	-	53(79)	63(95)	79(118)	5	2
				28	7.5	10.5	20	0.008 5	0.007 3	0.006					
				35	10	14	25	0.011 4	0.009 7	0.008					
				42	12.5	17.5	30	0.014 3	0.012 2	0.010 1					

					5			3	2	1						
5	GJZ 150×200	266	8.06	21	5	7	15	0.005	-	-	70(105)	84(126)	105(158)	5	2	
				28	7.5	10.5	20	0.006	0.005	0.005						
				35	10	14	25	7	7	0.006						
				42	12.5	17.5	30	0.008	0.007	0.006						
								9	7	4						
				42	12.5	17.5	30	0.011	0.009	0.008						
								2	6							
6	GJZ 150×250	336	8.84	28	7.5	10.5	20	0.005	0.005	-	88(131)	105(158)	131(197)	5	2	
				35	10	14	25	7	6	5						
				42	12.5	17.5	30	0.007	0.006	0.005						
								7	6	9						
				42	12.5	17.5	30	0.009	0.008	0.006						
								6	3							
7	GJZ 150×300	406	9.44	28	7.5	10.5	20	0.005	0.005	-	105(158)	126(189)	158(236)	5	2	
				35	10	14	25	2	0.006	0.006						0.005
				42	12.5	17.5	30	9	6	0.005						
								0.008	0.008	0.006						
				42	12.5	17.5	30	0.008	0.008	0.006						
								9	3	3						
8	GYZ d200	284	9.5	35	10	14	25	0.005	-	-	73(110)	88(132)	110(165)	5	2	
				42	12.5	17.5	30	1	0.006	0.005						0.005
				49	15	21	35	4	5	0.005						
				56	17.5	24.5	40	0.007	0.006	0.005						
								7	6	6						
				42	12.5	17.5	30	0.006	0.005	0.005						
								4	5							
				49	15	21	35	0.007	0.006	0.005						
								7	6	6						
				56	17.5	24.5	40	0.008	0.007	0.006						

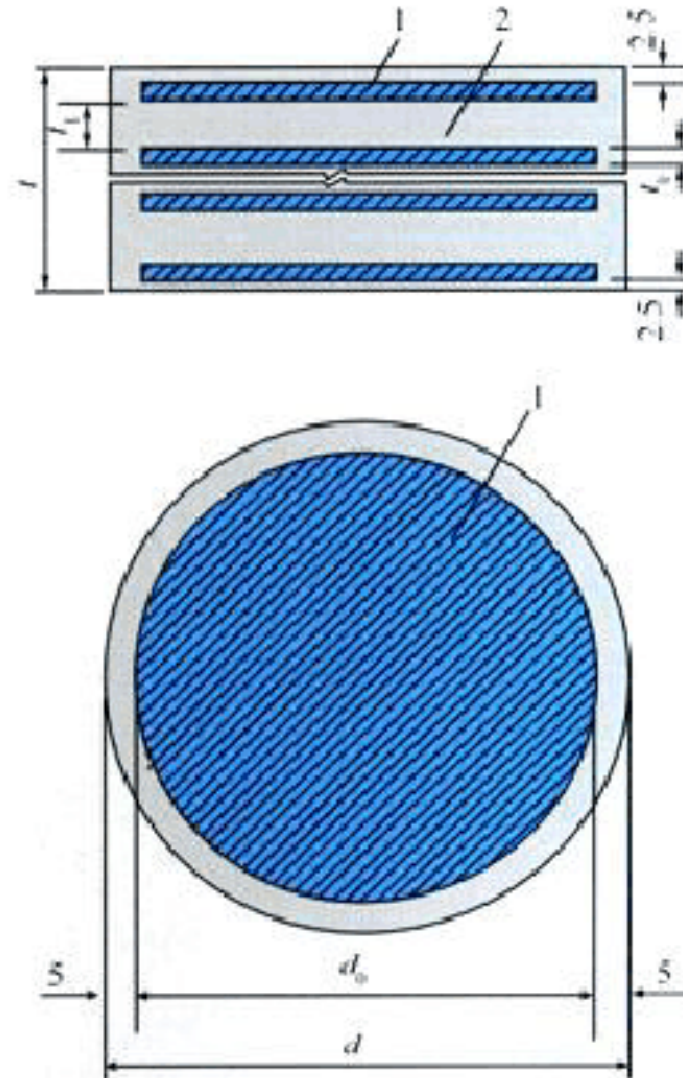
努力必有回报

					5			9	7	5					
9	GJZ 200×200	361	9.5	35	10	14	25	0.005 1	-	-	93(140)	112(168)	140(210)	5	2
				42	12. 5	17.5	30	0.006 4	0.005 5	0.005					
				49	15	21	35	0.007 7	0.006 6	0.005 6					
				56	17. 5	24.5	40	0.008 9	0.007 7	0.006 5					
1 0	GJZ 200×250	456	10.6	42	12. 5	17.5	30	0.005 4	0.005	-	117(175)	140(210)	175(263)	5	2
				49	15	21	35	0.006 4	0.005 6	0.005					
				56	17. 5	24.5	40	0.007 5	0.006 6	0.005 6					
1 1	GJZ 200×300	551	7.17	30	8	11.2	21	0.006 6	0.005 6	0.005	140(210)	168(252)	210(315)	8	3
				41	12	16.8	29	0.009 8	0.008 4	0.007					
				52	16	22.4	37	0.013 1	0.011 2	0.009 3					
1 2	GJZ 200×350	646	7.62	30	8	11.2	21	0.005 9	0.005 1	-	163(245)	196(294)	245(368)	8	3
				41	12	16.8	29	0.008 9	0.007 6	0.006 3					
				52	16	22.4	37	0.011 8	0.010 1	0.008 4					

努力必有回报

1 3	GJZ 200×400	741	7.98	30	8	11.2	21	0.005 5	0.005	-	187(280)	224(336)	280(420)	8	3
				41	12	16.8	29	0.008 2	0.007	0.005 9					
				52	16	22.4	37	0.010 9	0.009 3	0.007 8					
1 4	GYZ d250	452	7.5	41	12	16.8	29	0.007 3	0.006 2	0.005 2	115(172)	137(206)	172(258)	8	3
				52	16	22.4	37	0.009 7	0.008 3	0.006 9					
				63	20	28	45	0.012 1	0.010 4	0.008 6					
1 5	GJZ 250×250	576	7.5	41	12	16.8	29	0.007 3	0.006 2	0.005 2	146(219)	175(263)	219(328)	8	3
				52	16	22.4	37	0.009 7	0.008 3	0.006 9					
				63	20	28	45	0.012 1	0.010 4	0.008 6					
1 6	GJZ 250×300	696	8.21	41	12	16.8	29	0.006 2	0.005 4	0.005	175(263)	210(315)	263(394)	8	3
				52	16	22.4	37	0.008 3	0.007 1	0.006					
				63	20	28	45	0.014	0.008	0.007					

努力必有回报

								1	9	5					
				74	24	33.6	53	0.012	0.010	0.009					
								5	7						
1	GJZ	816	8.79	41	12	16.8	29	0.005	0.005	-					
								6							
				52	16	22.4	37	0.007	0.006	0.005					
								4	4	4					
7	250×350			63	20	28	45	0.009	0.008	0.006					
								3		7					
				74	24	33.6	53	0.011	0.009	0.008					
								1	6	1					
											204(306)	245(368)	306(459)	8	3
1	GJZ	936	9.29	41	12	16.8	29	0.005	-	-					
								1							
				52	16	22.4	37	0.006	0.005	0.005					
								8	9						
8	250×400			63	20	28	45	0.008	0.007	0.006					
								5	3	2					
				74	24	33.6	53	0.010	0.008	0.007					
								2	8	4					
											233(350)	280(420)	350(525)	8	3
1	GJZ	1056	9.71	41	12	16.8	29	0.005	-	-					
				52	16	22.4	37	0.006	0.005	0.005					
								3	5						
				63	20	28	45	0.007	0.006	0.006					
								9	8	2					
				74	24	33.6	53	0.009	0.008	0.007					
								5	2	4					
											263(394)	315(473)	394(591)	8	3
2	GJZ	1176	10.0	41	12	16.8	29	0.005	-	-					
											292(438)	350(525)	438(656)	8	3

努力必有回报

0	250×500		7	52	16	22.4	37	0.006	0.005	-						
									2							
				63	20	28	45	0.007	0.006	0.005						
				4	5	5										
				74	24	33.6	53	0.008	0.007	0.006						
								9	8	6						
2	GYZ d300	661	9.06	52	16	22.4	37	0.005	0.005	-	165(247)	198(297)	247(371)	8	3	
								9	1							
				63	20	28	45	0.007	0.006	0.005						
				4	3	3										
				74	24	33.6	53	0.008	0.007	0.006						
								8	6	4						
				85	28	39.2	61	0.010	0.008	0.007						
								3	9	5						
2	GJZ	841	9.06	52	16	22.4	37	0.005	0.005	-	210(315)	252(378)	315(473)	8	3	
								9	1							
				63	20	28	45	0.007	0.006	0.005						
				4	3	3										
				74	24	33.6	53	0.008	0.007	0.006						
								8	6	4						
				85	28	39.2	61	0.010	0.008	0.007						
								3	9	5						
2	GJZ	986	9.78	52	16	22.4	37	0.005	0.005	-	245(368)	294(441)	368(551)	8	3	
								2								
				63	20	28	45	0.006	0.005	0.005						
								5	6							
				74	24	33.6	53	0.007	0.006	0.005						

努力必有回报

								8	8	7					
				85	28	39.2	61	0.009	0.007	0.006					
								1	9	7					
2	GJZ	1131	10.4	52	16	22.4	37	0.005	-	-	280(420)	336(504)	420(630)	8	3
4	300×400			63	20	28	45	0.005	0.005	-					
				74	24	33.6	53	0.007	0.006	0.003					
				85	28	39.2	61	0.008	0.007	0.006					
								3	2	1					
2	GJZ	1276	10.9	63	20	28	45	0.005	0.005	-	315(473)	378(5670)	473(709)	8	3
5	300×450			74	24	33.6	53	0.006	0.005	0.005					
				85	28	39.2	61	0.007	0.006	0.005					
								5	6	7					
2	GJZ	1421	8.28	54	16.	23.1	38	0.007	0.006	0.005	350(525)	420(630)	525(788)	11	4
6	300×500			69	22	30.8	49	0.009	0.008	0.006					
				84	27.	38.5	60	0.011	0.010	0.008					
								4	1	8					
								7	1	4					
2	GJZ	1566	8.58	54	16.	23.1	38	0.006	0.005	0.005	385(578)	462(693)	578(866)	11	4
7	300×550			69	22	30.8	49	0.008	0.007	0.006					
				84	27.	38.5	60	0.011	0.009	0.008					
								6	7						
								8	6	4					

努力必有回报

					5				5	4					
2 8	GJZ 300×600	1711	8.64	54	16. 5	23.1	38	0.006 3	0.005 4	0.005	420(630)	504(756)	630(945)	11	4
				69	22	30.8	49	0.008 4	0.007 3	0.006 1					
				84	27. 5	38.5	60	0.010 5	0.009 1	0.007 6					
2 9	GYZ d350	908	10.6 3	63	20	28	45	0.005	-	-	224(337)	269(404)	337(505)	8	3
				74	24	33.6	53	0.005 9	0.005 1	-					
				85	28	39.2	61	0.006 8	0.006	0.005 1					
				96	32	44.8	69	0.007 8	0.006 8	0.005 8					
3 0	GJZ 350×350	1156	10.6 3	63	20	28	45	0.005	-	-	286(429)	343(515)	429(643)	8	3
				74	24	33.6	53	0.005 9	0.005 1	-					
				85	28	39.2	61	0.006 8	0.006	0.005 1					
				96	32	44.8	69	0.007 8	0.006 8	0.005 8					
3 1	GJZ 350×400	1326	8.26	54	16. 5	23.1	38	0.006 1	0.005 2	-	327(490)	392(588)	490(735)	11	4
				69	22	30.8	49	0.008 1	0.006 9	0.005 8					
				84	27. 5	38.5	60	0.010 1	0.008 7	0.007 3					

努力必有回报

				99	33	46.2	71	0.020	0.010	0.008					
				1				1	4	7					
3	GJZ	1496	8.72	54	16.	23.1	38	0.005	0.005	-	368(551)	441(662)	551(827)	11	4
				5				5							
				69	22	30.8	49	0.007	0.006	0.005					
				4				4	4	3					
2	350×450			84	27.	38.5	60	0.009	0.007	0.006					
				5				2	9	7					
				99	33	46.2	71	0.011	0.009	0.008					
				1				1	5						
3	GJZ	1666	9.12	54	16.	23.1	38	0.005	-	-	408(613)	490(735)	613(919)	11	4
				5				1							
				69	22	30.8	49	0.006	0.005	0.005					
				9				9	9						
3	350×500			84	27.	38.5	60	0.008	0.007	0.006					
				5				6	4	2					
				99	33	46.2	71	0.010	0.008	0.007					
				3				3	9	5					
3	GJZ	1836	9.48	54	16.	23.1	38	0.005	-	-	449(674)	539(809)	674(1011)	11	4
				5											
				69	22	30.8	49	0.006	0.005	0.005					
				4				4	6						
4	350×550			84	27.	38.5	60	0.008	0.007	0.005					
				5				1		9					
				99	33	46.2	71	0.009	0.008	0.007					
				7				7	4	1					
3	GJZ	2006	9.8	54	16.	23.1	38	0.005	-	-	490(735)	588(882)	735(1103)	11	4

				99	33	46.2	71	0.008	0.007	0.006					
								6	4	3					
				114	38.5	53.9	82	0.01	0.008	0.007					
									6	3					
3	GJZ	1911	9.87	69	22	30.8	49	0.005	0.005	-					
								3							
				84	27.5	38.5	60	0.006	0.005	0.005					
								6	7						
9	400×500			99	33	46.2	71	0.007	0.006	0.005	467(700)	560(840)	700(1050)	11	4
								9	9	8					
				114	38.5	53.9	82	0.009	0.008	0.006					
								2		8					
4	GJZ	2106	10.2	69	22	30.8	49	0.005	-	-					
				84	27.5	38.5	60	0.006	0.005	0.005					
								2	4						
0	400×550		9	99	33	46.2	71	0.007	0.006	0.006	513(770)	616(924)	770(1156)	11	4
								4	5	5					
4	GJZ	2301	10.6	69	22	30.8	49	0.005	-	-					
				84	27.5	38.5	60	0.005	0.005	-					
								8	1						
1	400×600		7	99	33	46.2	71	0.007	0.006	0.005	560(840)	672(1008)	840(1260)	11	4
									1	2					
4	GJZ	2490	11.0	69	22	30.8	49	0.005	-	-					
				84	27.5	38.5	60	0.005	0.005	-					
								6							
2	400×650		2	99	33	46.2	71	0.006	0.005	0.005	607(910)	728(1092)	910(1365)	11	4
								7	8						

努力必有回报

4 3	GYZ d450	1521	10	69	22	30.8	49	0.005	-	-	371(557)	445(668)	557(835)	11	4
				84	27.	38.5	60	0.005	0.005	-					
				5				7							
				99	33	46.2	71	0.006	0.006	0.005					
				9		1									
				114	38.	53.9	82	0.008	0.007	0.005					
				5						9					
4 4	GJZ 450×450	1936	10	69	22	30.8	49	0.005	-	-	473(709)	567(851)	709(1063)	11	4
				84	27.	38.5	60	0.005	0.005	-					
				5				7							
				99	33	46.2	71	0.006	0.006	0.005					
				9		1									
				114	38.	53.9	82	0.008	0.007	0.005					
				5						9					
4 5	GJZ 450×500	2156	10.5 4	84	27.	38.5	60	0.005	0.005	-	525(788)	630(945)	788(1299)	11	4
				5				3							
				99	33	46.2	71	0.006	0.005	0.005					
				4		5									
				114	38.	53.9	82	0.007	0.006	0.005					
				5				4	5	5					
4 6	GJZ 450×550	2376	11.0 2	84	27.	38.5	60	0.005	-	-	578(866)	693(1040)	866(1299)	11	4
				5											
				99	33	46.2	71	0.005	0.005	-					
				9		2									
				114	38.	53.9	82	0.006	0.006	0.005					
				5				9	1	2					
4	GJZ	2596	8.4	70	22.	31.5	50	0.006	0.005	0.005	630(945)	756(1134)	945(1418)	15	5

努力必有回报

7	450×600			5			2	4							
				90	30	42	65	0.008	0.007						0.006
				110	37.5	52.5	80	0.010	0.009						0.007
4 8	GJZ 450×650	2816	8.69	70	22.5	31.5	50	0.005	0.005	-	683(1024)	819(1229)	1024(1536)	15	5
				90	30	42	65	0.007	0.006	0.005					
				110	37.5	52.5	80	0.009	0.008	0.007					
4 9	GYZ d500	1886	8.17	70	22.5	31.5	50	0.005	0.005	-	458(687)	550(825)	687(1031)	15	5
				90	30	42	65	0.007	0.006	0.005					
				110	37.5	52.5	80	0.009	0.008	0.007					
				130	45	63	95	0.011	0.010	0.008					
5 0	GJZ 500×500	2401	8.17	70	22.5	31.5	50	0.005	0.005	-	583(875)	700(1050)	875(1313)	15	5
				90	30	42	65	0.007	0.006	0.005					
				110	37.5	52.5	80	0.009	0.008	0.007					
				130	45	63	95	0.011	0.010	0.008					

努力必有回报

5 1	GJZ 500×550	2646	8.56	70	22. 5	31.5	50	0.005 4	0.005	-	642(963)	770(1155)	963(1444)	15	5
				90	30	42	65	0.007 3	0.006 3	0.005 2					
				110	37. 5	52.5	80	0.009 1	0.007 8	0.006 6					
				130	45	63	95	0.010 9	0.009 4	0.007 9					
5 2	GJZ 500×600	2891	8.92	70	22. 5	31.5	50	0.005 1	-	-	700(1050)	840(1269)	1050(1575)	15	5
				90	30	42	65	0.006 8	0.005 9	0.005					
				110	37. 5	52.5	80	0.008 5	0.007 3	0.006 2					
				130	45	63	95	0.010 2	0.008 8	0.007 7					
5 3	GJZ 500×650	3136	9.25	70	22. 5	31.5	50	0.005	-	-	758(1138)	910(1365)	1138(1706)	15	5
				90	30	42	65	0.006 4	0.005 5	0.005					
				110	37. 5	52.5	80	0.008 0.008	0.006 9	0.005 8					
				130	45	63	95	0.009 6	0.008 3	0.007					
5 4	GJZ 500×700	3381	9.55	70	22. 5	31.5	50	0.005	-	-	817(1225)	980(1470)	1225(1838)	15	5
				90	30	42	65	0.006	0.005	-					

								1	3								
				110	37.5	52.5	80	0.0076	0.0066	0.0056							
				130	45	63	95	0.0091	0.0079	0.0067							
5	GYZ d550	2290	9	90	30	42	65	0.0061	0.0052	-	554(832)	665(998)	832(1247)	15	5		
5				110	37.5	52.5	80	0.0076	0.0066	0.0055							
				130	45	63	95	0.0091	0.0079	0.0066							
				150	52.5	73.5	110	0.0106	0.0092	0.0077							
5	GJZ 550×550	2916	9	90	30	42	65	0.0061	0.0052	-	706(1059)	847(1271)	1059(1588)	15	5		
6				110	37.5	52.5	80	0.0076	0.0066	0.0055							
				130	45	63	95	0.0091	0.0079	0.0066							
				150	52.5	73.5	110	0.0106	0.0092	0.0077							
5	GJZ 550×600	3186	9.4	90	30	42	65	0.0057	0.005	-	770(1155)	924(1386)	1155(1733)	15	5		
7				110	37.5	52.5	80	0.0071	0.0061	0.0052							
				130	45	63	95	0.0085	0.0073	0.0062							

努力必有回报

以上内容仅为本文档的试下载部分，为可阅读页数的一半内容。如要下载或阅读全文，请访问：
<https://d.book118.com/577115045125006141>