

OTIS (TT)测试工具的使用方法

☆ Toec-40 调试方法

[概要] 由于本工具可与若干种 OTIS 公司的电梯（如：TOEC-40 TOEC-60 等）连接。本说明书仅以与 TOEC-40 型电梯相连时为例，与其它电梯相连时略有不同。

测试工具接在 LB（逻辑板）上，因此它可以一边登记一边检查轿厢的状况和各个输入输出。

[功能]

- 1.LED 检查
- 2.各状态的显示（轿厢状况，门状况，轿厢位置，方向，呼梯）
- 3.呼梯的登记
- 4.输入的显示
- 5.输出的操作
- 6.各轿厢的状况（组件）
- 7.存储器(RAM)内存内容的显示

[显示部]

显示窗：有 16×2 个 LCD 显示屏，显示出英文和数字。

[键]

[MOUDULE]	对线路板进行选择。
[DISP STATE]	显示轿厢状况，门状况。
[ENT CALL]	登记呼梯。
[TEST]	不用。
[FUNTION]	不用。
[DISP IN]	输入显示。
[SEL OUT]	输出操作。
[0] ~ [9]	呼梯登记的楼层输入。
[SET]	不用。
[ON]	使输出接通。
[UP] [DOWN]	上，下呼梯。
[蓝键]	换档键。
[OFF]	使输出断开。
[GO ON]	显示后面的输入，输出状况。
[GO BACK]	显示后面的输入，输出状况。

使用方法

1. LCD 检查（自身测试）

[功能] 实验 LCD 的显示机能

[使用方法]

(1) 由于接通 LB（逻辑板），自动开始 LCD 顺次点灯实验。

(2) 在使用实验工具进行的情况下，按动红色的转换开关。

2. 轿厢状况，门状况的显示：

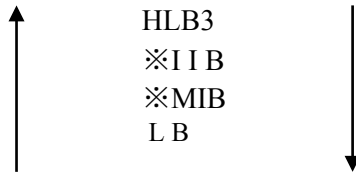

3) 按动[DISP IN]键时，显示这块线路板最初的输入

IIB	/FST	ON
线路板	输入	输入状态

4) 使用[GO ON], [GO BACK]想要检查的输入被显示出来

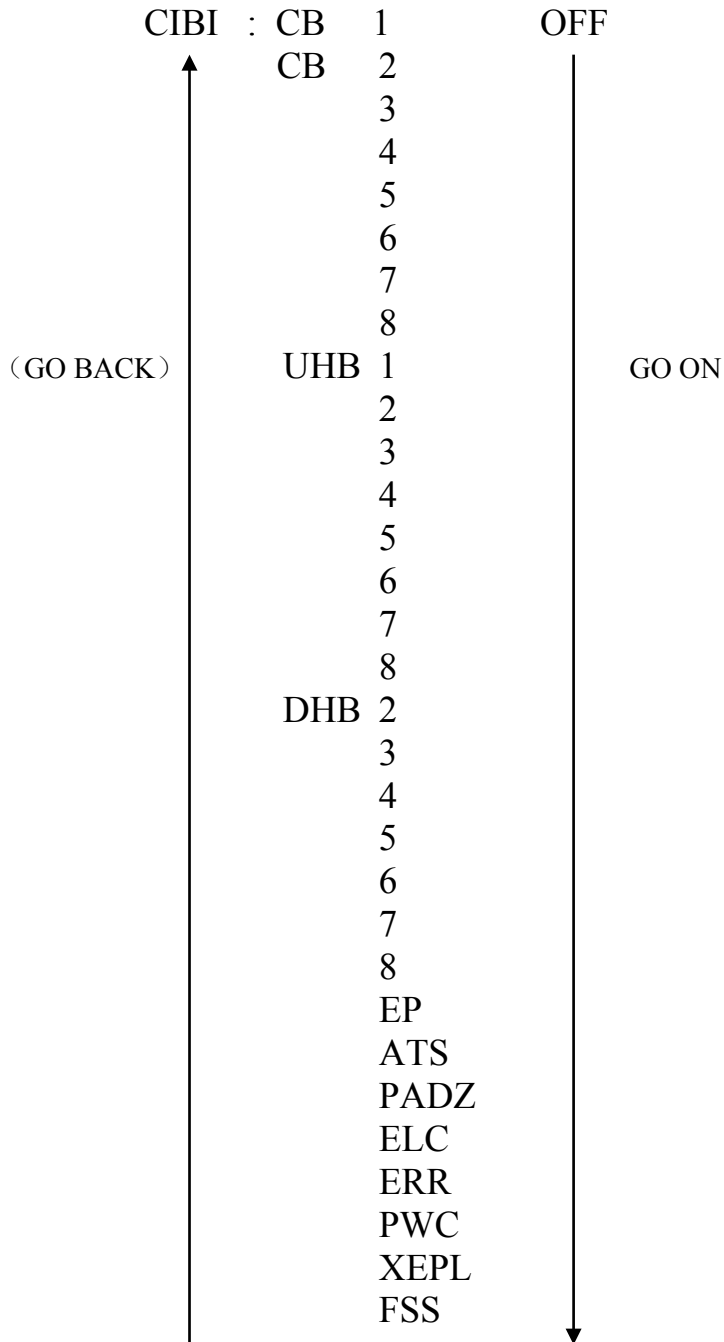

CIB2:

CB

9

10

11

12

13

14

15

16

UHB

9

10

11

12

13

14

15

16

DHB

9

10

11

12

13

14

15

16

线路板

输入

/FST

/IP

/DRV

/URV

ACS

IUB

IDB

DOHB

LRU

TR1

TR2

TR3

PKS

ISS

ANSS

LWS

LNS

TIU

TID

(GO BACK)

GO ON

(GO BACK)

由计数板来的输入
由计数板来的输入
由计数板来的输入
由计数板来的输入

GO ON

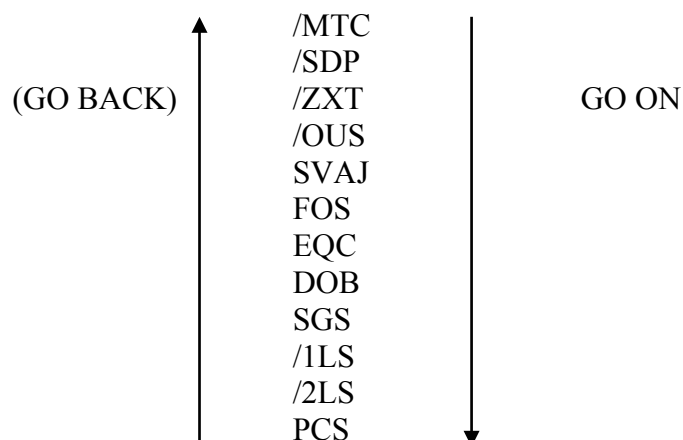

[注意]带 / 符号的输入表示在 OFF 时其功能起作用。

5 输出的操作

[机能] 开关 TTB , EPB , SGB 的输出。

[使用方法]

- 1) 按动[MOUDULE]键
- 2) 用[GO ON], [GO BACK]键, 选择线路板 (参考输入显示这项)
- 3) 按动[SEL OUT]键显示 TTB CTL 1
- 4) 由[GO ON],[GO BACK]键, 选择希望 ON , OFF 的输出。
- 5) 用[ON],[OFF] 键时输出的 ON 或 OFF。

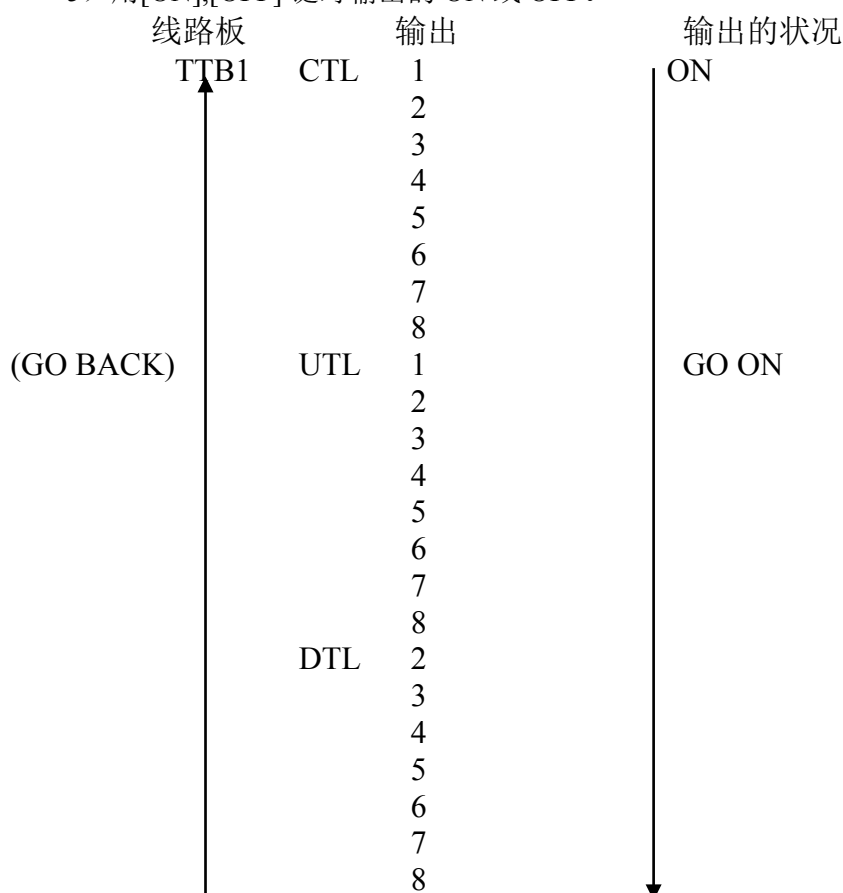

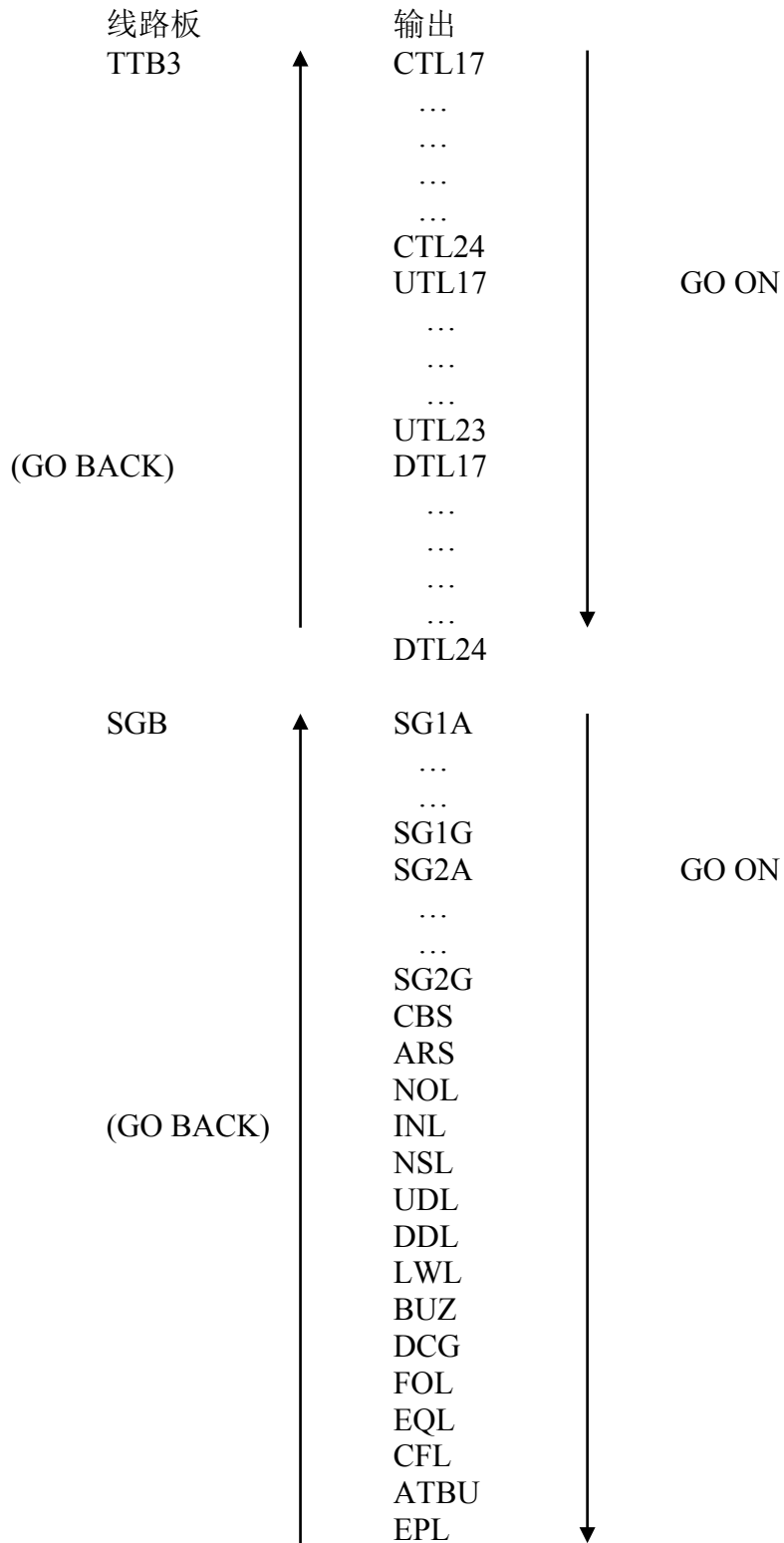

[注意] SGB, EPB 的输出接通 (ON) 时, 因为微机定期地输出位置的信号, 所以指示器只能在一瞬间接通或断开。

这时，即使对于 SGB，EPB 的继电器的声音也能确认。

6. 轿厢状况的显示（只限于群组）

[功能] 显示被接通的那号机的轿厢状况，轿厢呼唤，大厅呼梯。

[使用方法]

1) 接通 A 号机或者 B 号机

2) 按动[DISP STATE] 键

3) 按动[GO ON]键时，显示如下：

A 号 轿厢的状况

4) A 号机接通的情况下，只能动[GO ON]键时，就显示 B 号机的情况。

[轿厢状况的内容]

T: 轿厢在恒速进行中 (TRAVELLING)

NT: 轿厢在停止或减速中 (NOT TRAVELLING)

E: 轿厢不满员 (EMPTY)

NE: 轿厢满员 (NOT IMMEDIATE)

I: 轿厢不延迟 (IMMEDIATE)

NI: 轿厢过一段时间再开 (NOT IMMEDIATE)

A: 轿厢可能一组运转 (AVAILABLE)

NA: 分别（独立）运转 (NOT AVAILABLE)

R: 轿厢可以正常运转 (READY)

NR: 轿厢有故障 (NOT READY)

7. 存储器内容的显示

[功能] 数据在 RAM 指定位置显示。（在 RAM 的最初部分记入发生故障的次数。）

[使用方法]

1) 按动[DISP STATE]键

2) 两次按动[GO ON]键时，显示如下：

8□□□ □□ □1 F1 F1

光头位置（8000H） 8000H 的数据 8001H 的数据 8002H 的数据 8003H 的数据

3) 是先头位置向 100H 位置进时，按动[GO ON]键，恢复时，按[GO BACK]键。

4) 制定先头位置的下两位时，使用[1]～[0]键。

5) 使先头位置进到 1 位置时，使用[UP]键，恢复时使用[DOWN]键。

位置 内容

8000H	LB(逻辑板) 错误的次数
8001H	TRV 停止的次数
8002H	SAF 停止的次数
8003H	ESS 停止的次数
8004H	DFC 停止的次数
8005H	SDP 停止的次数
8006H	SDP 停止的次数
8007H	OUS 停止的次数
8008H	变成 MTC 的次数
8009H	变成 CNS 的次数
800AH	变成 DZ 的次数
800BH	变成 IP 的次数
800CH	援救次数(不到 DZ 时)

800DH	援救次数 (走过 DZ 时)
800EH	援救次数 (DFC 停止时)
800FH	援救次数 (ESS 停止时)
8010H	TPC 停止次数
8011H	FST 停止次数
8012H	行走中 ZXT 断开的次数

※※注意※※

※RAM 的位置为 8000H~83FFH

※H 表示满意 16 进制

※位置和次数的数字用 16 进制表示

AH→10 DH→13

BH→11 EH→14

CH→12 FH→15

关于新型 IIB 的状态表示方法

1983 年秋以后出厂的 IIB 中装有表示状态的 LED，由 1983 年 8 月 1 日以后的 EPROM 程序表示。

显示	状况	实验工具的显示
□	等待运行控制电源供应	TRV?
	等 5 秒后，便开始校正运行	CORR?
2	等待呼梯信号	CALL?
3	运行中	RUN
4	轿厢换速而未进 DZ	DZ?
5	轿厢换速进入 DZ，但未完全停车	ZXT?
6	轿厢处于检修状态	INS
□·	急停开关被打开	ESS
8	轿厢处于救援操作	RESCU
9	轿厢处于平层操作	RLV
□·	马达热保护接点断路	MTC
F	轿厢处于地震操作	EQO
□·	轿厢处于消防操作	FOS
F·	轿厢因急停而处于减速，但未完全停止	EMERG!
□·	经过五次救援操作	FAIL!
□·	大厅锁梯开关	PKS
□·	安全回路断路	SAF?
□·	失去 IP 操作	MIP?
□·	因 OUS 动作而停止中	OUS?
□·	因 SDP 动作而停止中	SDP?

※ 门完全闭着时,各显示灯点亮,门没有完全关闭时,显示灯一闪一灭。

Mechanical Design

2 Mechanical Design

The mechanical design of the Service Tool is shown in Figure 2-1.

The Service Tool consists of two rows display with 16 columns each
And a keyboard with 16 keys.

The Tool is connected to the LCB_II over a RS 422 serial communication line.

MCS-LCB_II 调试方法

MCS-LCB_II Service Tool Manual

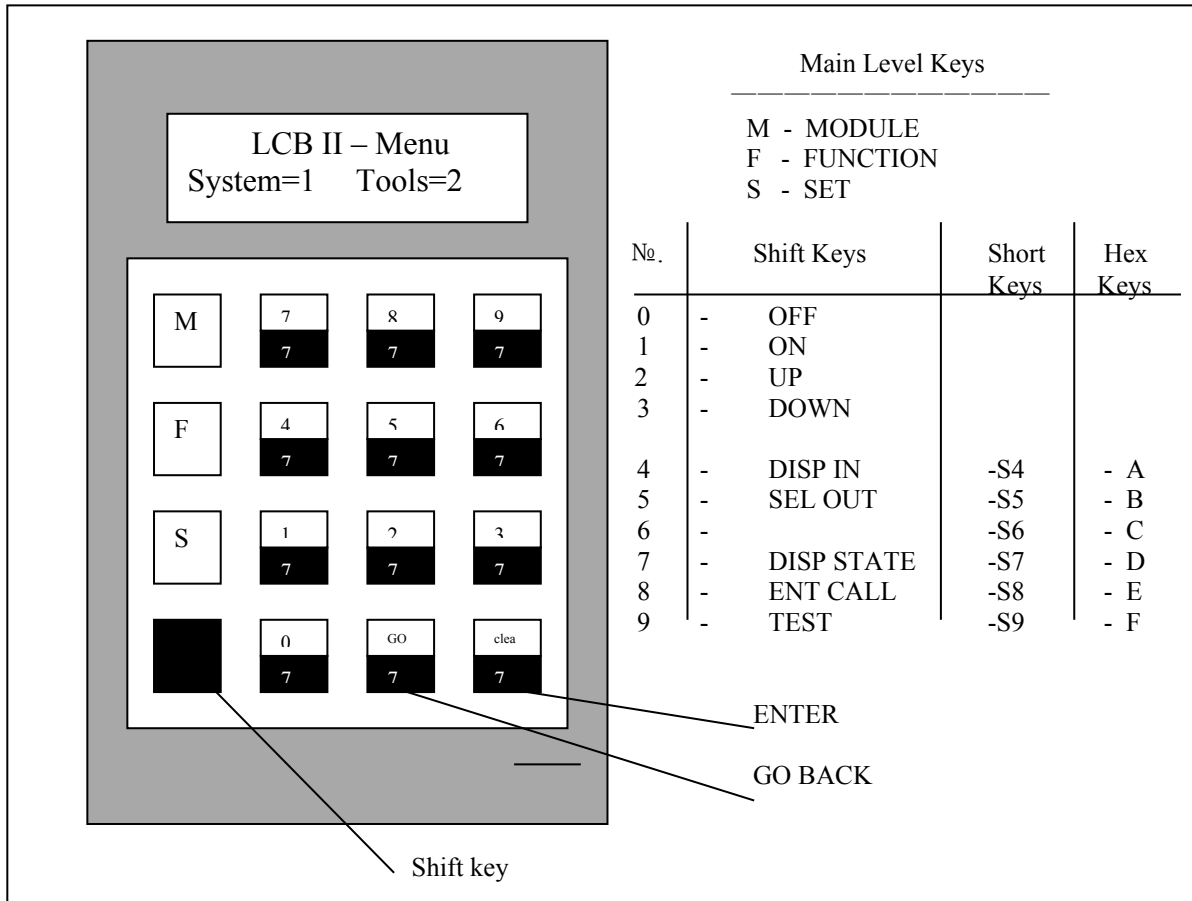

Tree Structure

3 Tree Structure

All Service tool functions are organized under the tree –structure – structure
Which you can see in **Figure 3-1**.

It is divided in a **SYSTEM** path ,where you have access to the main service
Tool functions – **STATUS** (system monitoring)

- **TEST** (event monitoring tests) and
- **SETUP**(setup of system environment),and in a **TOOLS** path.

The **TOOLS** pass contains the Service Tool functions which supports installation and maintenance of the elevator.

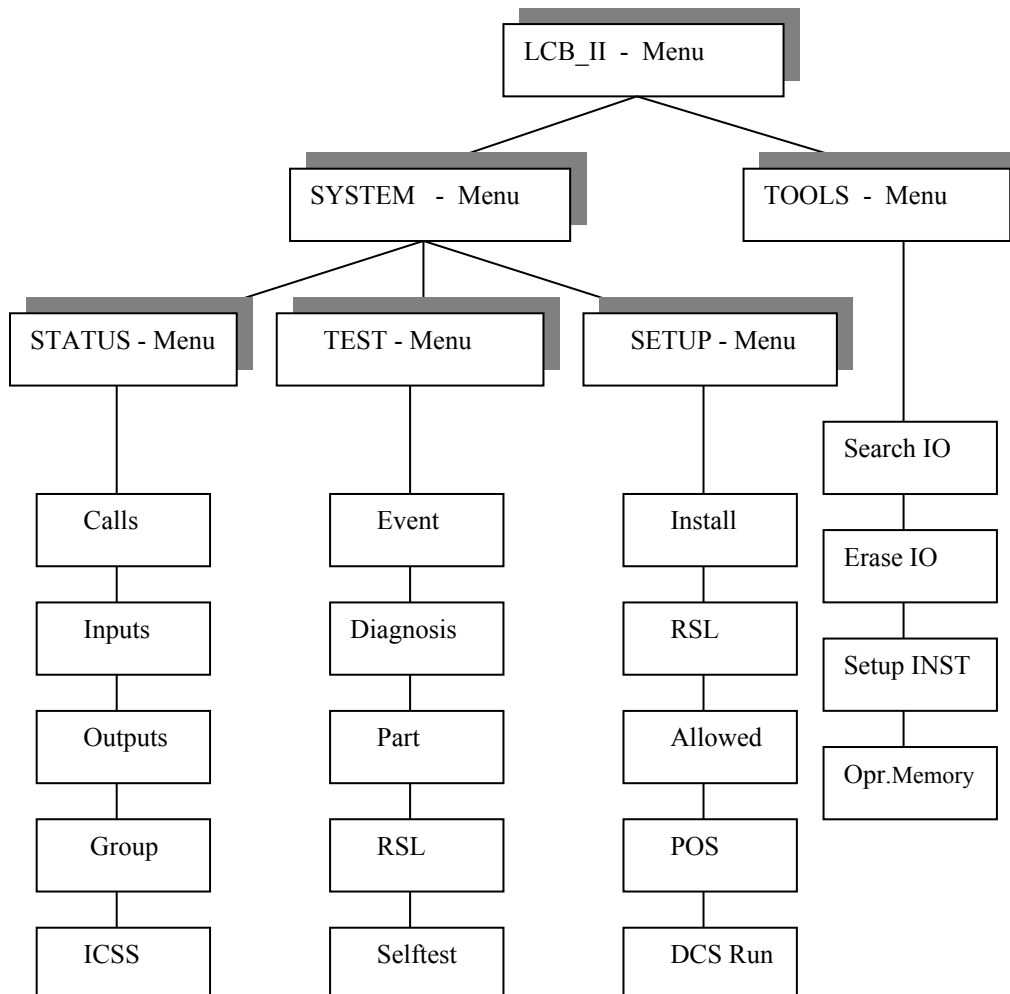

Cmd

ELD

4

Menu System

4 LCB_II Menu System

4.1 *OVERVIEW*

The Menu System allows you to access the single Server Tool functions if you choose the right path through the Tree-Structure by pressing the displayed key.(number **1,2,3... 8**)

If there is only one number to choose .you can call the function also with the Shift Key '**ENTER**'.

You can toggle between the different Menus using the '**GO ON**' or '**GO BACK**' key if the '>' character indicates a hidden menu.

The '**CLEAN**' key lets you jump one step back.

If you want to jump back to the one of the three Main Level of the architecture,(MONITOR, FUNCTION or SET) you can do it with the '**M**','**F**' or '**S**' Main Level Key.

The LCB_II Menu System is shown in **Figure 4 – 1.**

Power on →

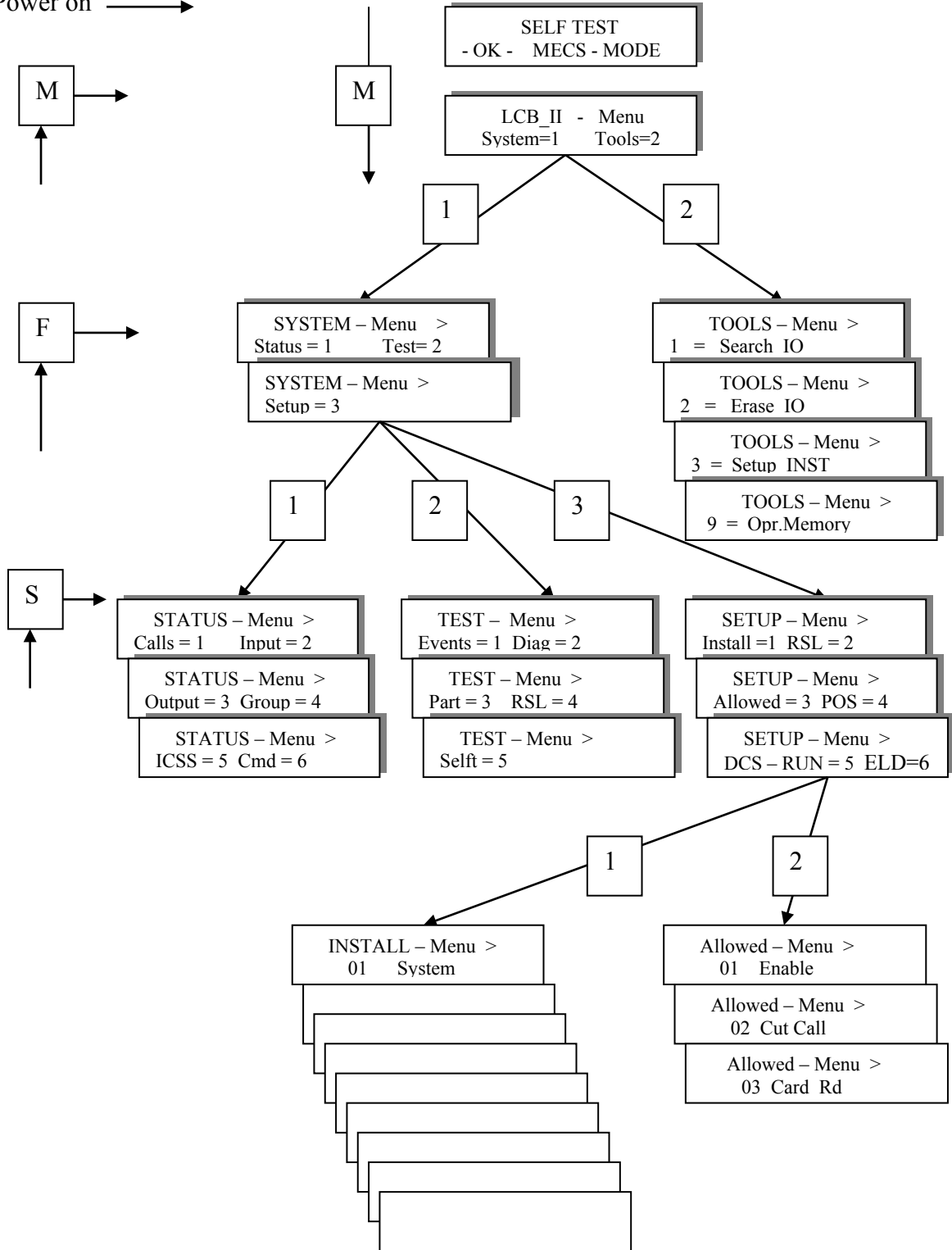
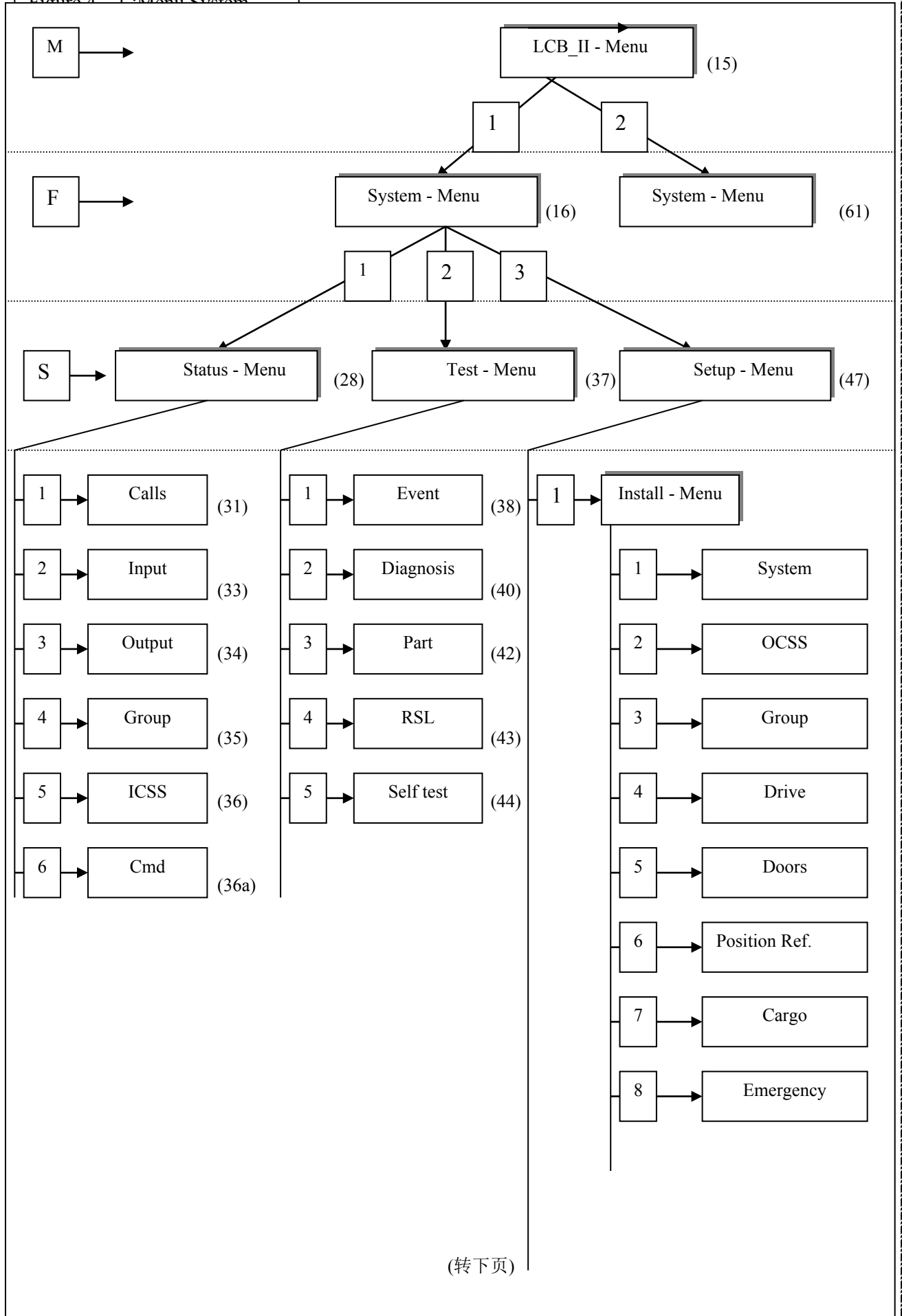
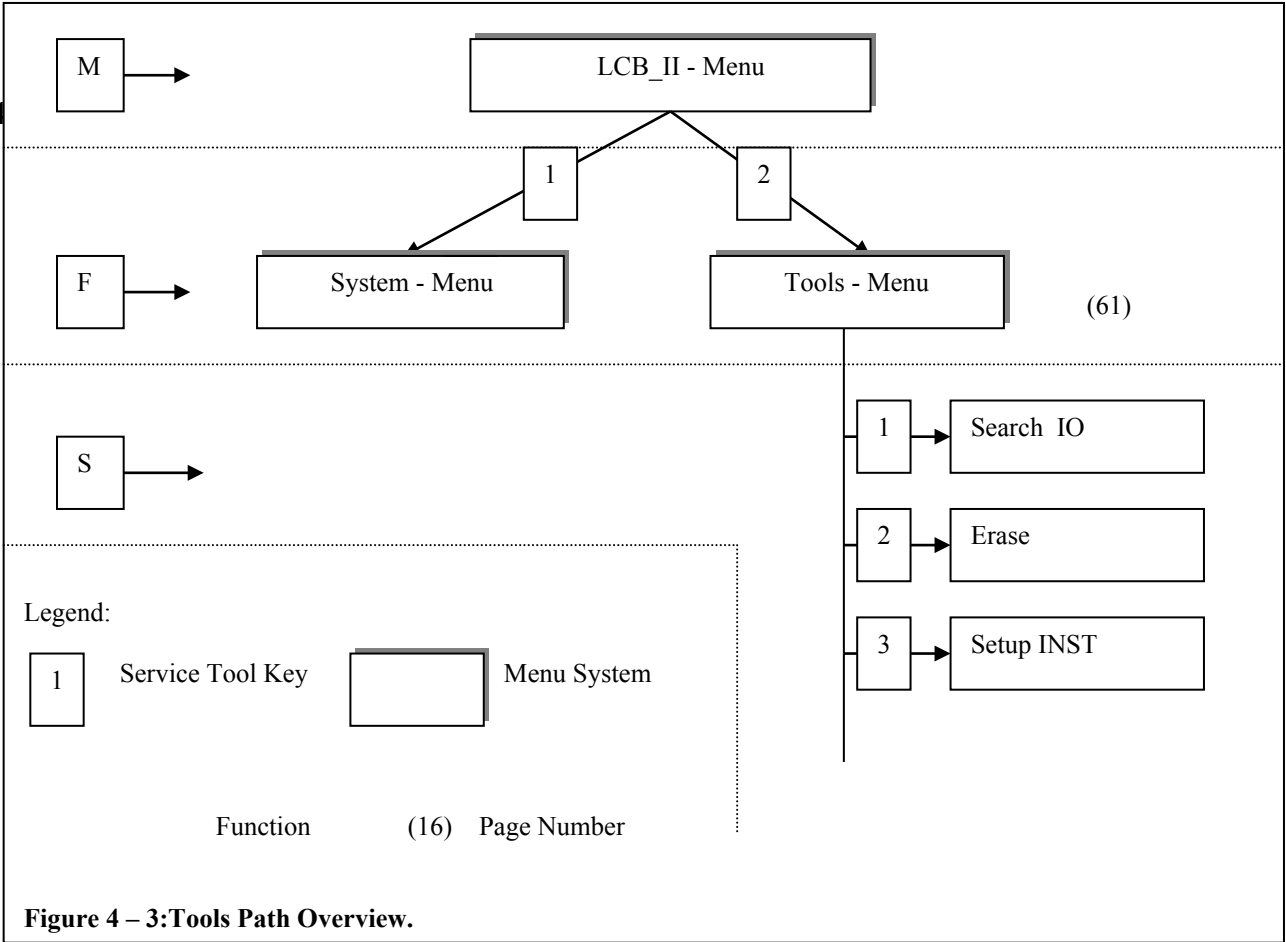
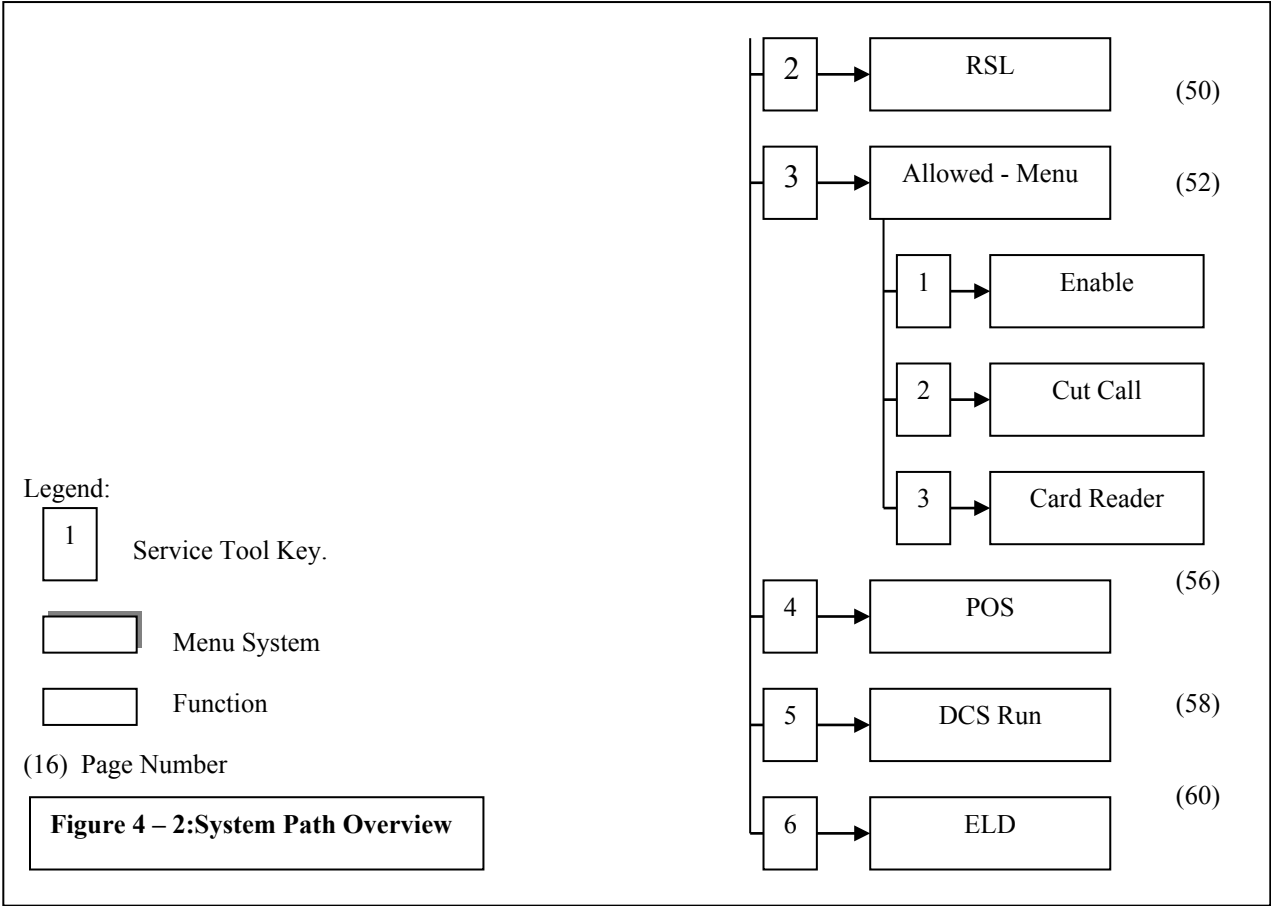

Figure 4-1: Menu System



(转下页)



4.2 LCB_II – Menus

4.2.1 Power On

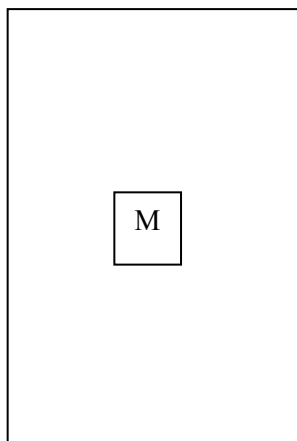
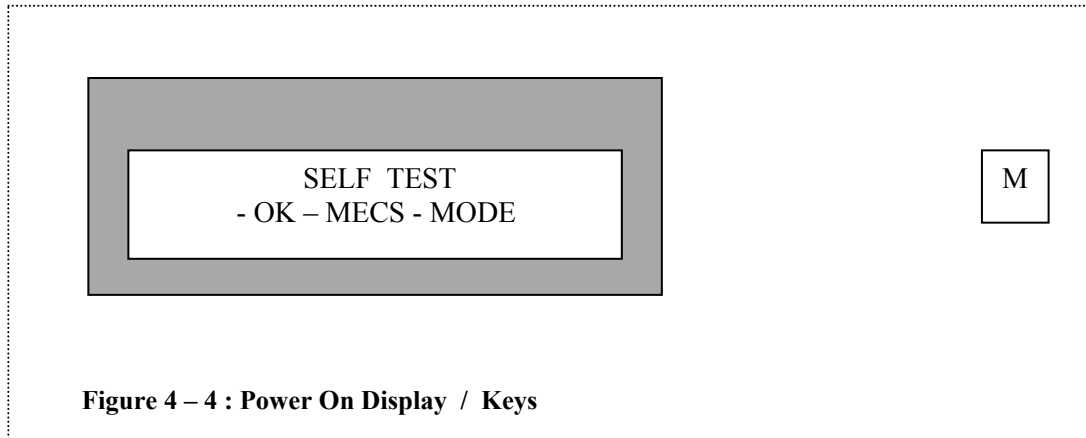

After Power On the Service Tool software runs an internal selftest.

The display shown in **figure 4 – 4** indicates a synchronized communication with the LCB_II and a successful selftest. The Service Tool is in operation now.

- Key MODULE:
Transition to the LCB_II – Menu.

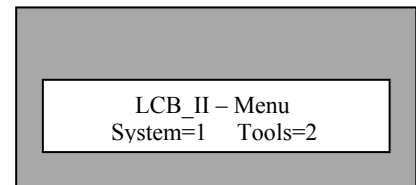

4.2.2 LCB_II - Menu

Key Sequence

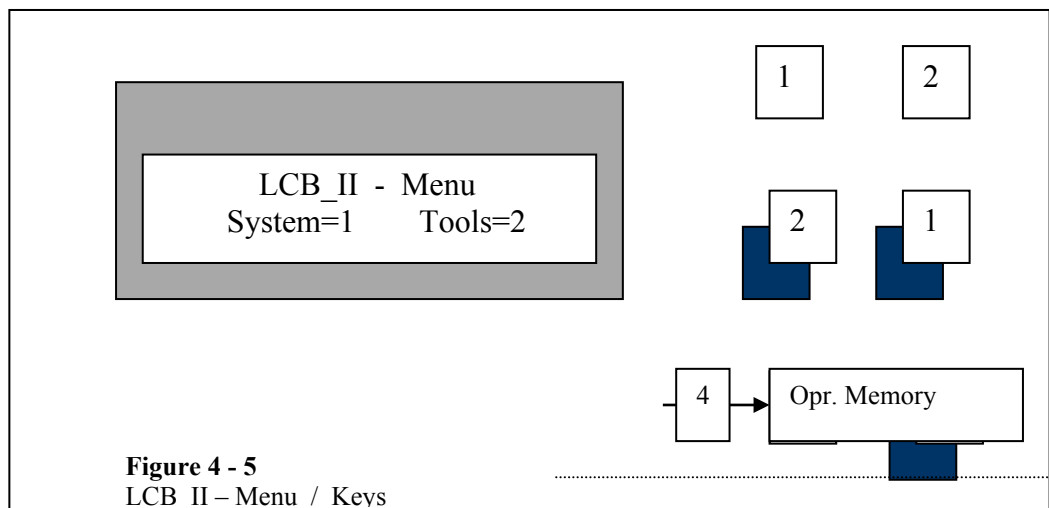
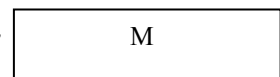

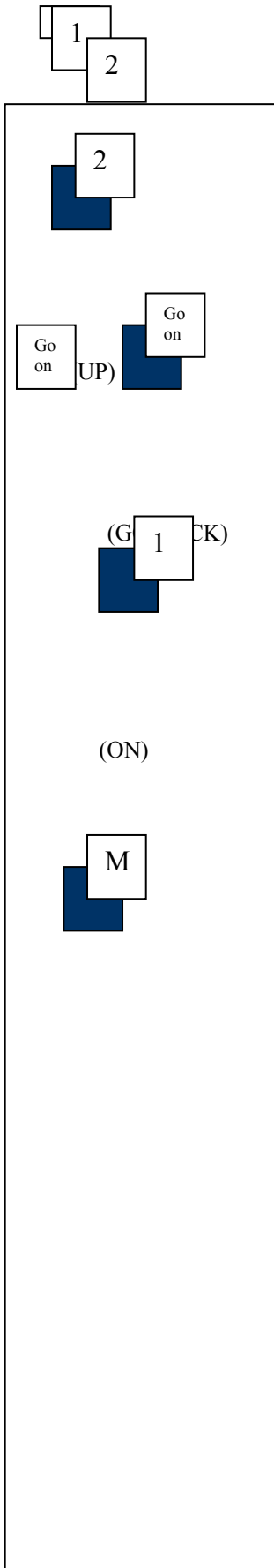

Key 1: transition to the SYSTEM – Menu
 Key2 : transition to the TOOLS – M

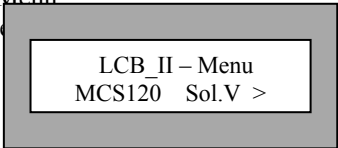

shift Key **UP** :display the current
 <toggle key> Controller Type
 and Drive Type.

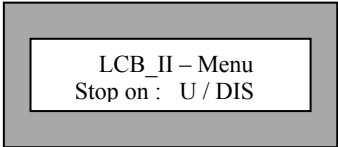

Key **GO ON** :displays the current
 <toggle key> stop signal(s)

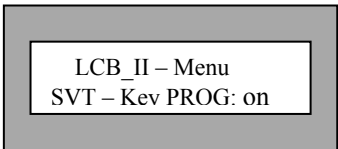

(see document : Service Tool
 reference List / Info Messages)

Shift key **ON**: displays the current
 state of the
 programmable
 Short Key S9

Shift key **OFF**: removes display
See:4.3 Short Keys

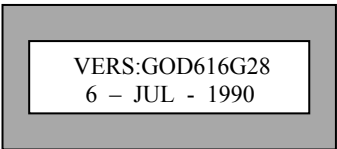

Shift key and **MONITOR**:
 Displays the revision and date of
 the Service Tool Firmware.

4.2.3 SYSTEM - Menu

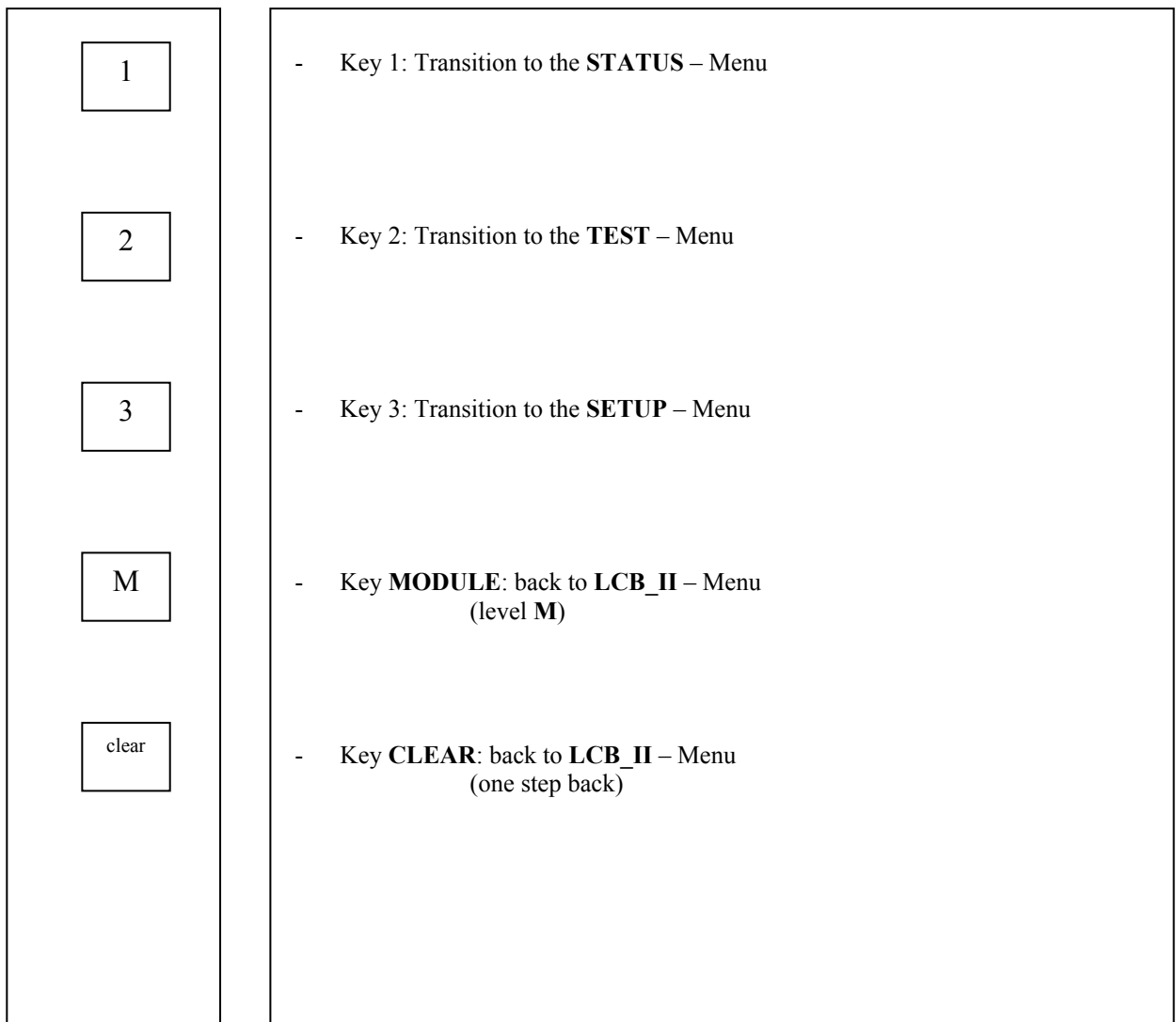
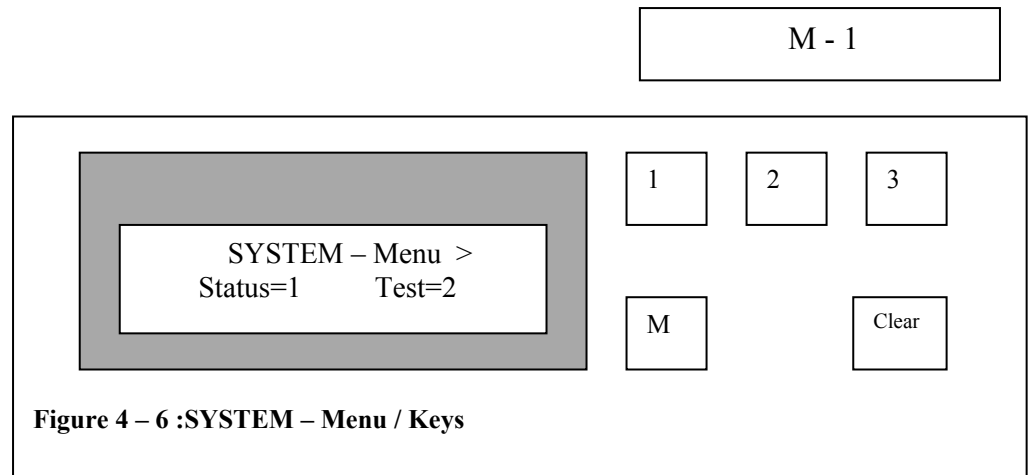

M - 1 - 1

4.2.4 STATUS - Menu

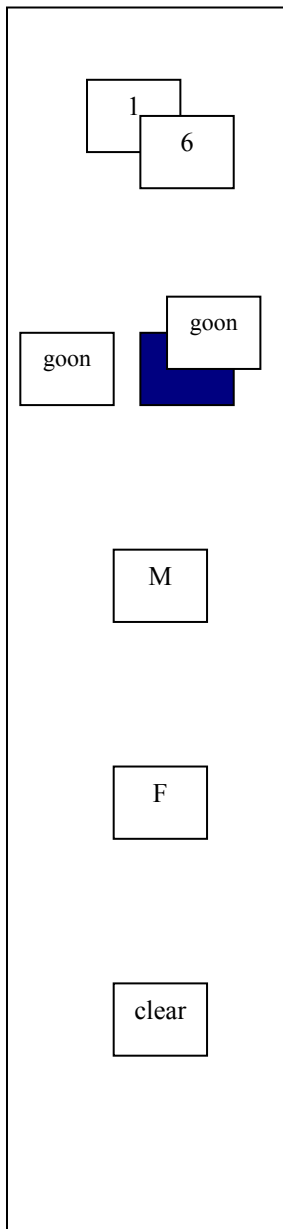
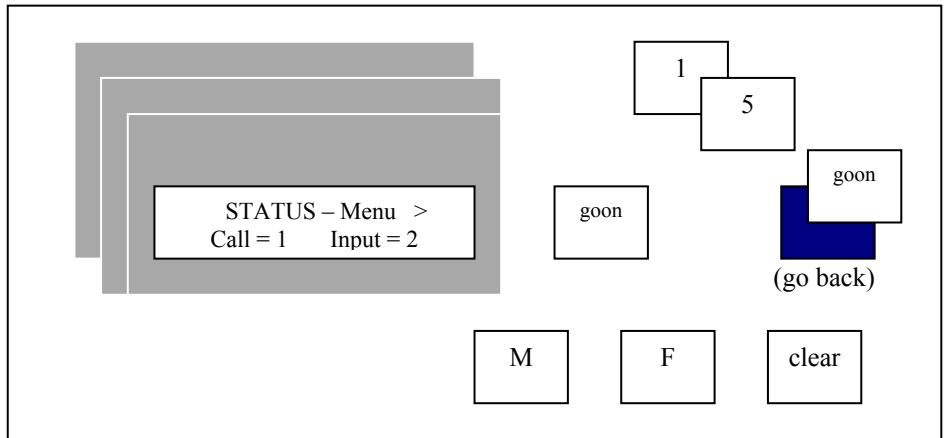

- **Key1** or **Key2**: Call of service Tool function **Calls** or **input**.
- **Key3** or **Key4**: Call of service Tool function **Output** or **Group**.
- **Key5**: Call of service Tool function **ICSS**.
- **Key6**: Call of service Tool function **Cmd**.

- Key **GOON** / **Shift Key GOBACK**: Toggle through **STATUS - Menu**

notice: ('>' indicates Menu - Toggle)

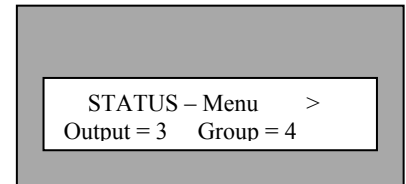

- Key **MODULE**: back to **LCB_II** Menu (level **M**)
- Key **FUNCTION**: back to **SYSTEM - Menu** (level **F**)
- Key **CLEAR**: back to **SYSTEM - Menu** (one step back)

M - 1 - 2

4.2.5 TEST - Menu

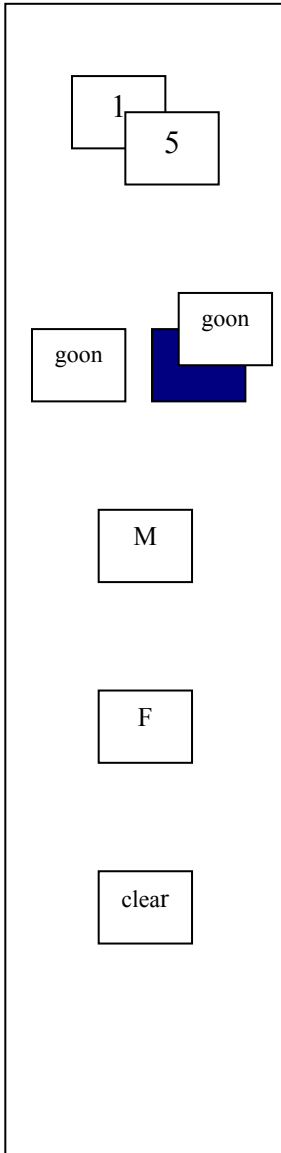
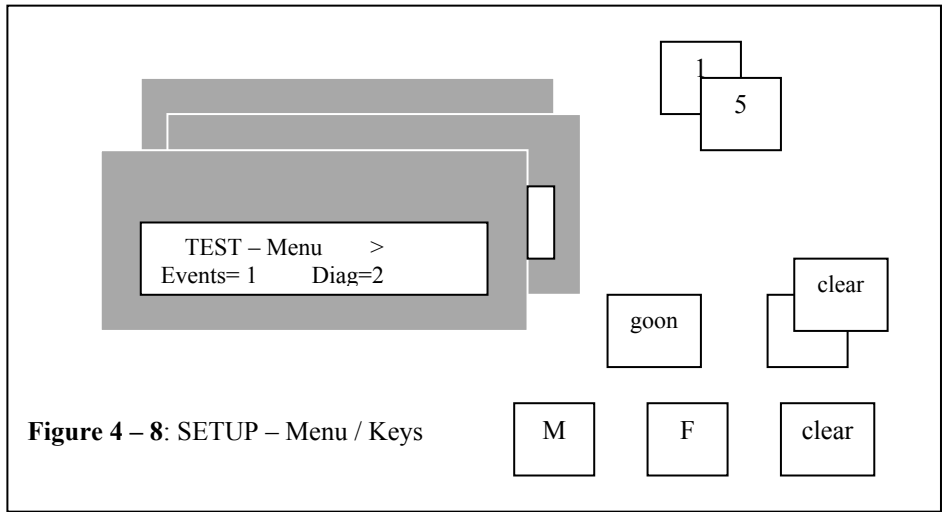

- Key 1 or 2: Transition to the **Events - or Diagnosis - Func.**
- Key 3 or 4: Transition to the **Part - or RSL - Func.**
- Key 5: Call of Selftest.

- Key **GOON** / Shift Key **GOBACK**:
Toggle though **SETUP - Menu**

notice: ('>' indicates Menu - Toggle)

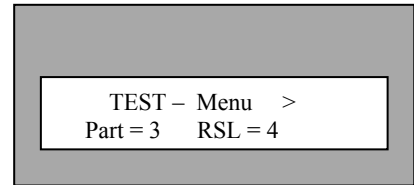

- Key **MODULE**: back to **LCB_II - Menu**
(level **M**)

- Key **FUNCTION**: back to **SYSTEM - Menu**
(level **F**)

- Key **CLEAR**: back to **SYSTEM - Menu**
(one step back)

M - 1 - 3

4.2.6 SETUP - Menu

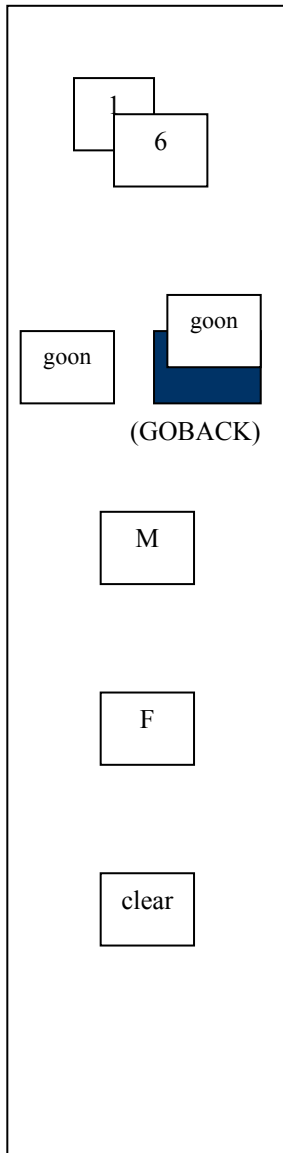
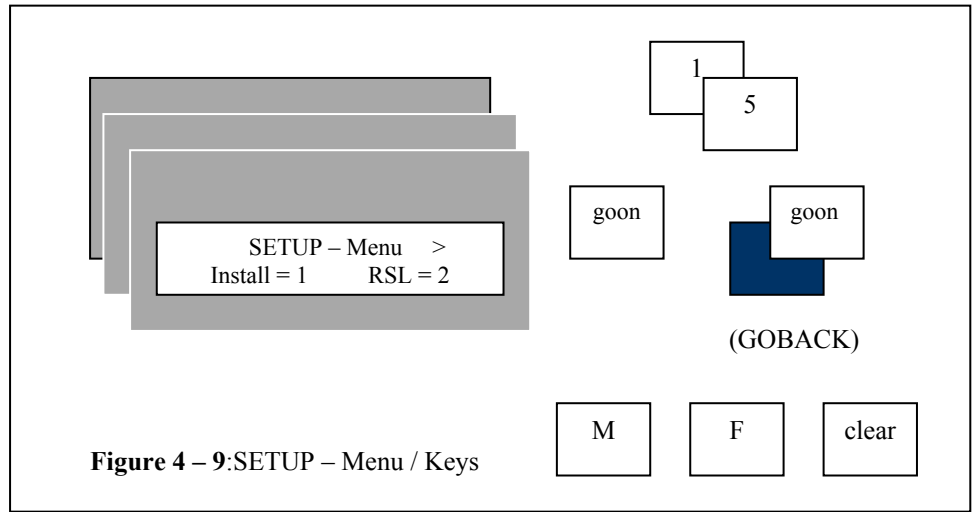

- Key 1 or 2: Transition to the **INSTALL - Menu** or **RSL - Func.**
- Key 3 or 4: Transition to the **ALLOWED - Menu** or **Pos - Func.**
- Key 5 or 6: Call of Service Tool Function **DCS - Run** or **ELD - Func.**

- Key **GOON** / Shift Key **GOBACK**: Toggle through **SETUP - Menu**

Notice: (<'> indicates Menu - Toggle)

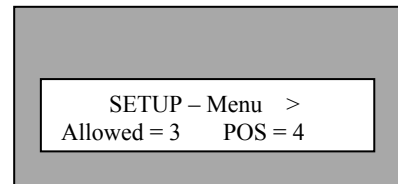

- Key **MODULE**: back to **LCB_II - Menu** (level **M**)

- Key **Function**: back to **System - Menu** (level **F**)

- Key **CLEAR**: back to **System - Menu** (one step back)

4.2.7 *Install - Menu*

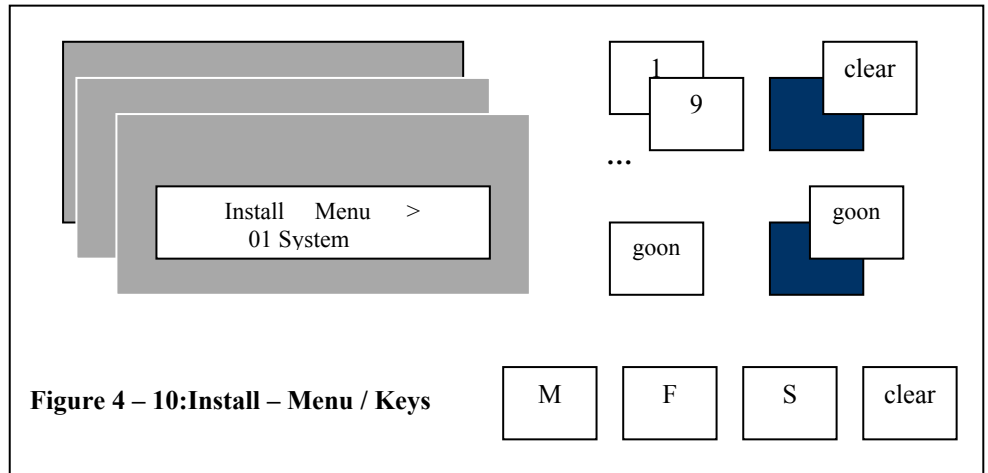
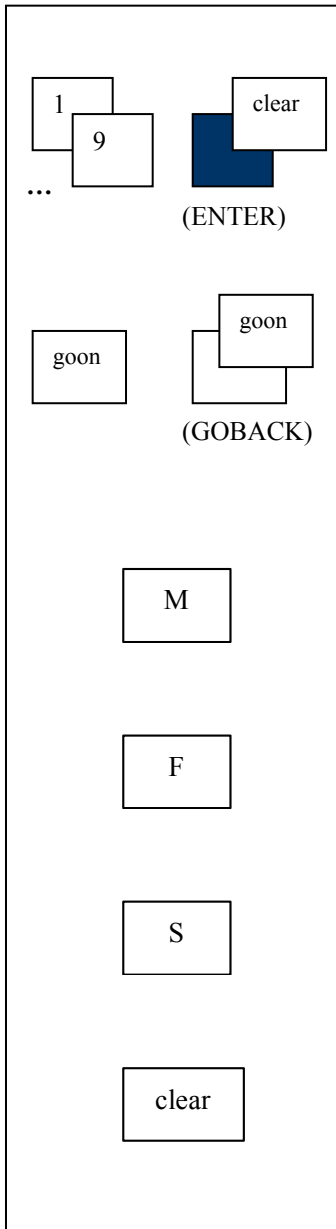

Figure 4 – 10: Install – Menu / Keys



- Key ... Key 9: Call of the Service Tool function **INSTALL –SYSTEM ... Install – Security**. (Please call **Install – Test** with **Key ENTER**)
- Shift Key **ENTER**: Call of the displayed Service Tool function.

- Key **GOON** / Shift Key **GOBACK**: Toggle through **INSTALL - Menu**

notice : ('>' indicates Menu – Toggle)

- Key **MODULE**: back to **LCB_II – Menu** (level **M**)

- Key **FUNCTION**: back to **SYSTEM – Menu** (level **F**)

- Key **SET**: back to **SETUP – Menu** (level **S**)

- Key **CLEAR**: back to **SETUP – Menu** (one step back)

4.2.8 ALLOWED

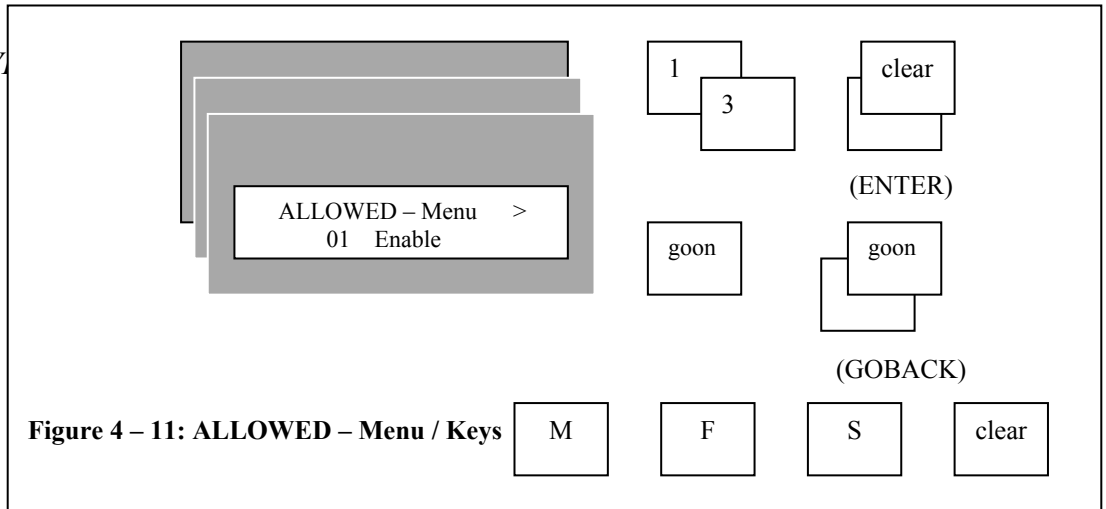
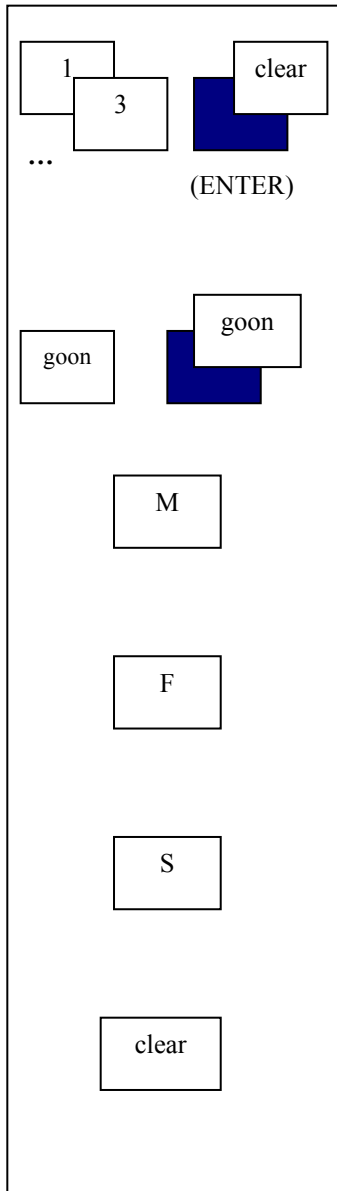

Figure 4 - 11: ALLOWED - Menu / Keys



- **Key 1:** Call of the Service Tool function Allowed - Enable
- ... **Key 3:** ...or the other 2 function of the **ALLOWED - Menu**
- Shift Key **ENTER:** Call of the display Service Tool function

- Key **GOON** / Shift Key **GOBACK:**
Toggle through **ALLOWED - Menu**

- Key **MODULE:** back to **LCB_II - Menu** (level **M**)

- Key **FUNCTION:** back to **SYSTEM - Menu** (level **F**)

- Key **SET:** back to **SETUP - Menu** (level **S**)

- Key **CLEAR:** back to **SETUP - Menu** (one step back)

4.2.9 TOOLS – Menu

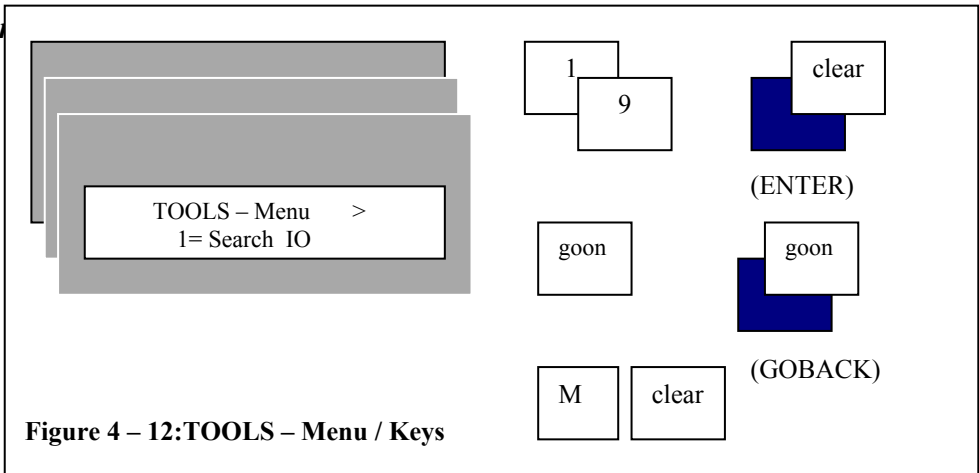
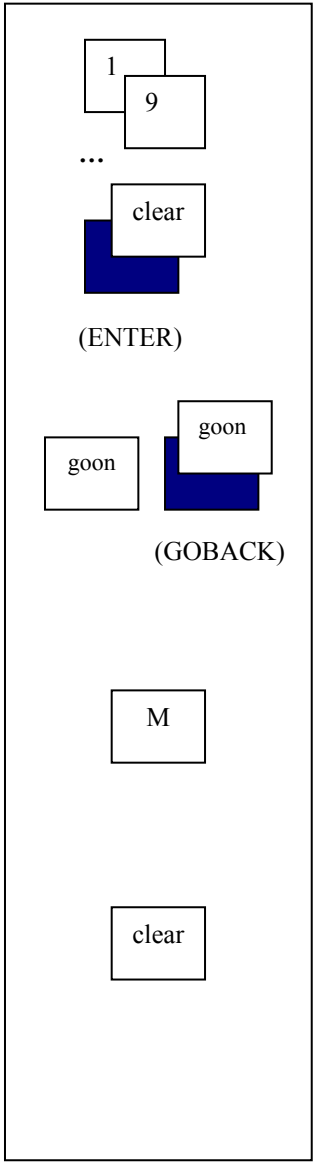

Figure 4 – 12:TOOLS – Menu / Keys



- Key 1: Call of Service Tool function Search IO.
 - Key 2,3 or 9: Call function Erase IO, SETUP INST or Opr. Memory

 - Shift Key ENTER: Calls the displayed Service Tool function.

 - Key GOON / Shift Key GOBACK: Toggle through TOOLS - Menu notice: ('>' indicates Menu – Toggle).
- TOOLS – Menu >
02 = Erase IO
- Key MODULE: back to LCB_II – Menu (level M)

 - Key CLEAR: back to LCB_II – Menu (one step back)

4.3 Short Keys

Short Keys

The Short Keys provide direct access to certain, often used Service Tool functions, eliminating the need to step through the menu structure.

The Service Tool functions **Input**, **Call**, **Install**, **Alter** and **Events** are assigned to the Standard Short Keys **S7** (Shift 7), **S8** (Shift 8), **S4** (Shift 4), **S5** (Shift 5) and **S6** (Shift 6).

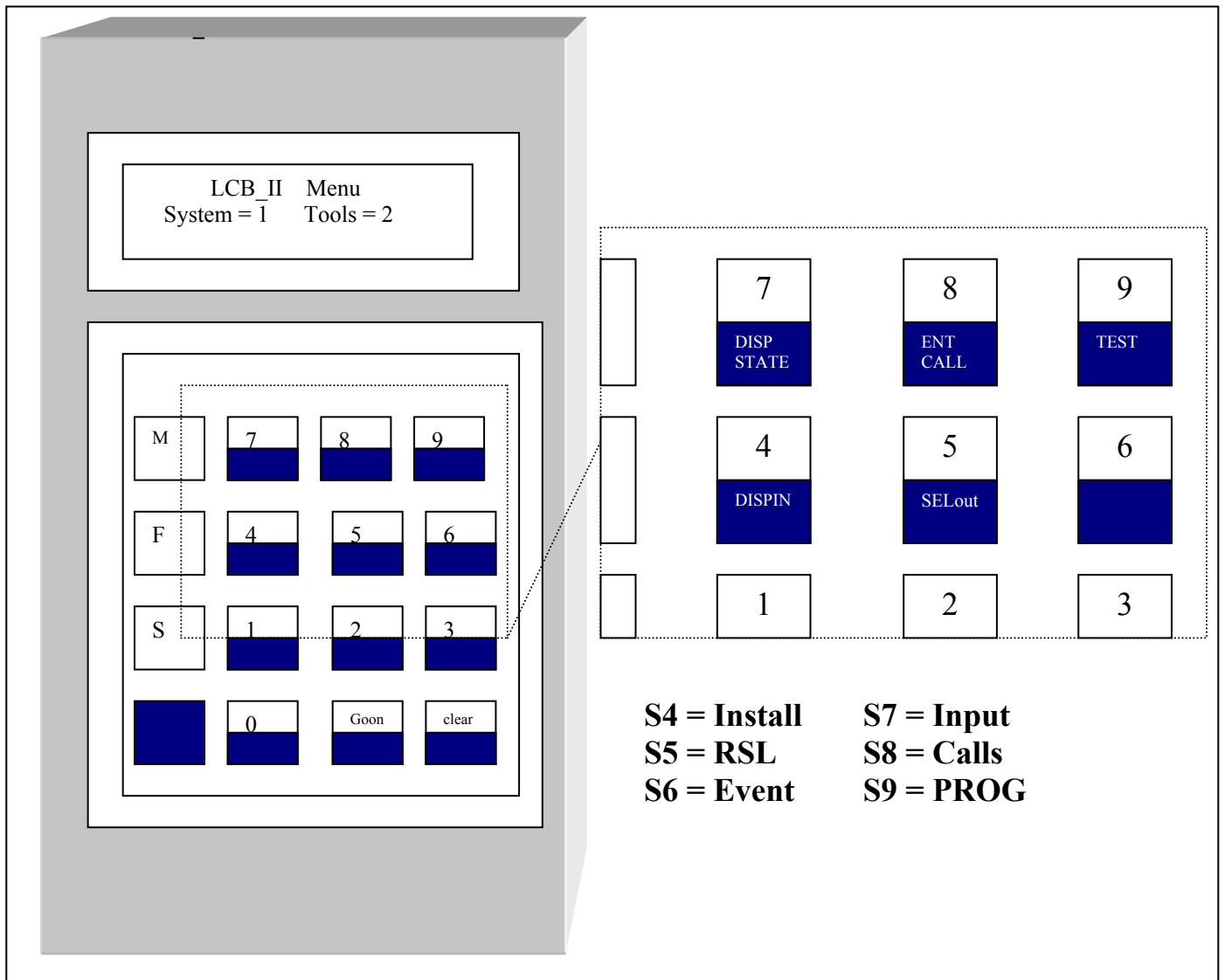

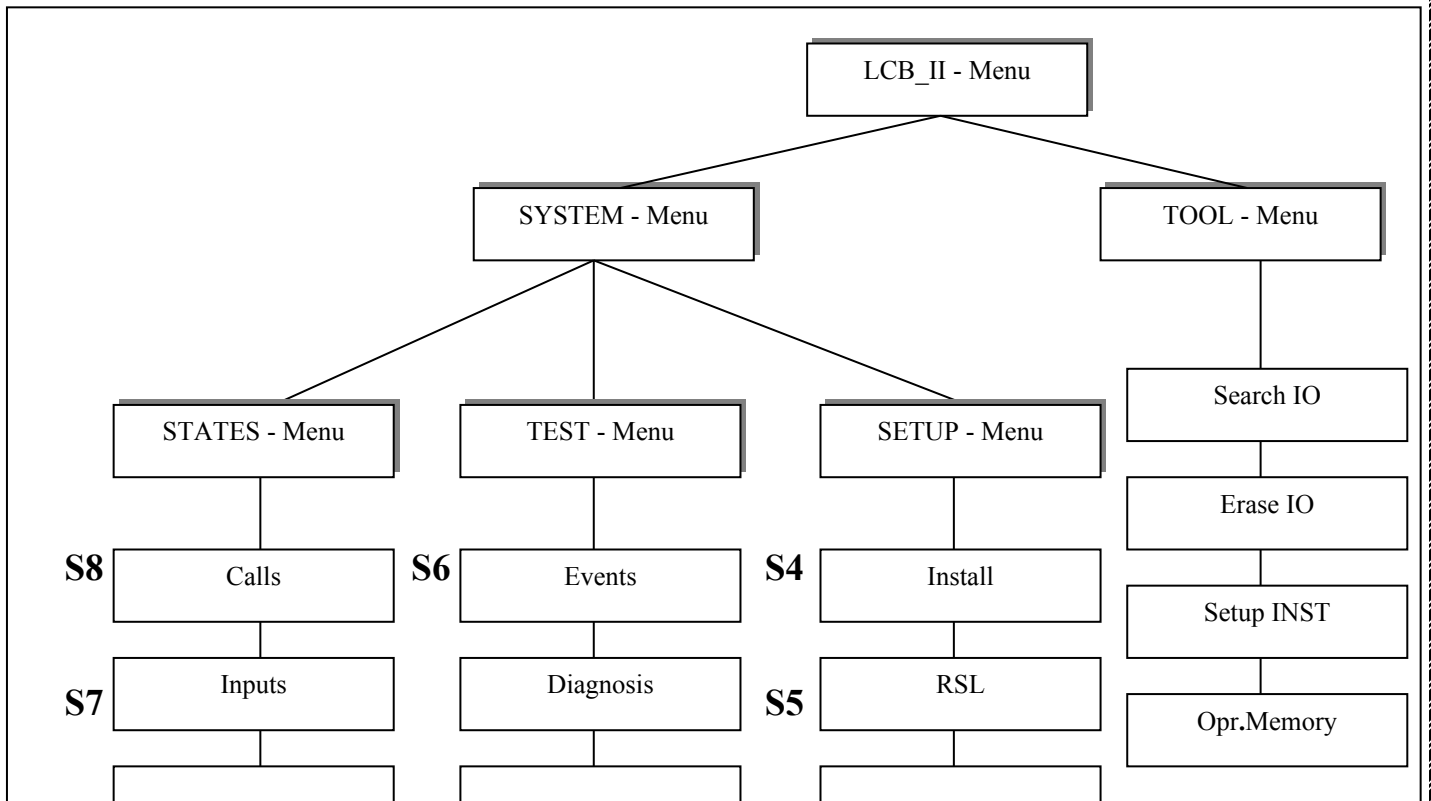
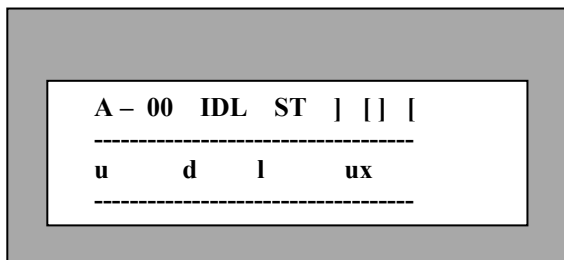
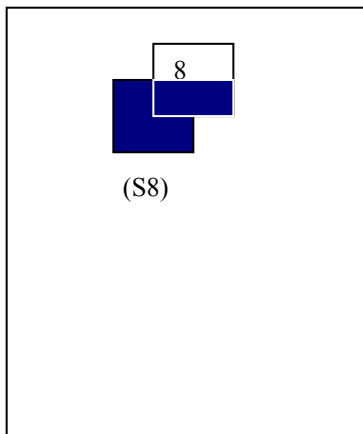

Figure 4 – 14: Standard Short Keys S4, S5, S7, S8 and S9.



The current function may be **STATUS / Output**



- Short Key S8: Direct call of function **STATUS / Calls**.
(see chapter: 5.1.2)

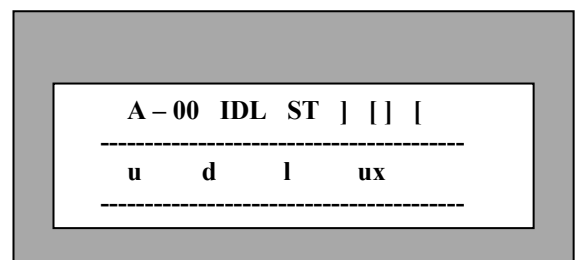

PROG S9

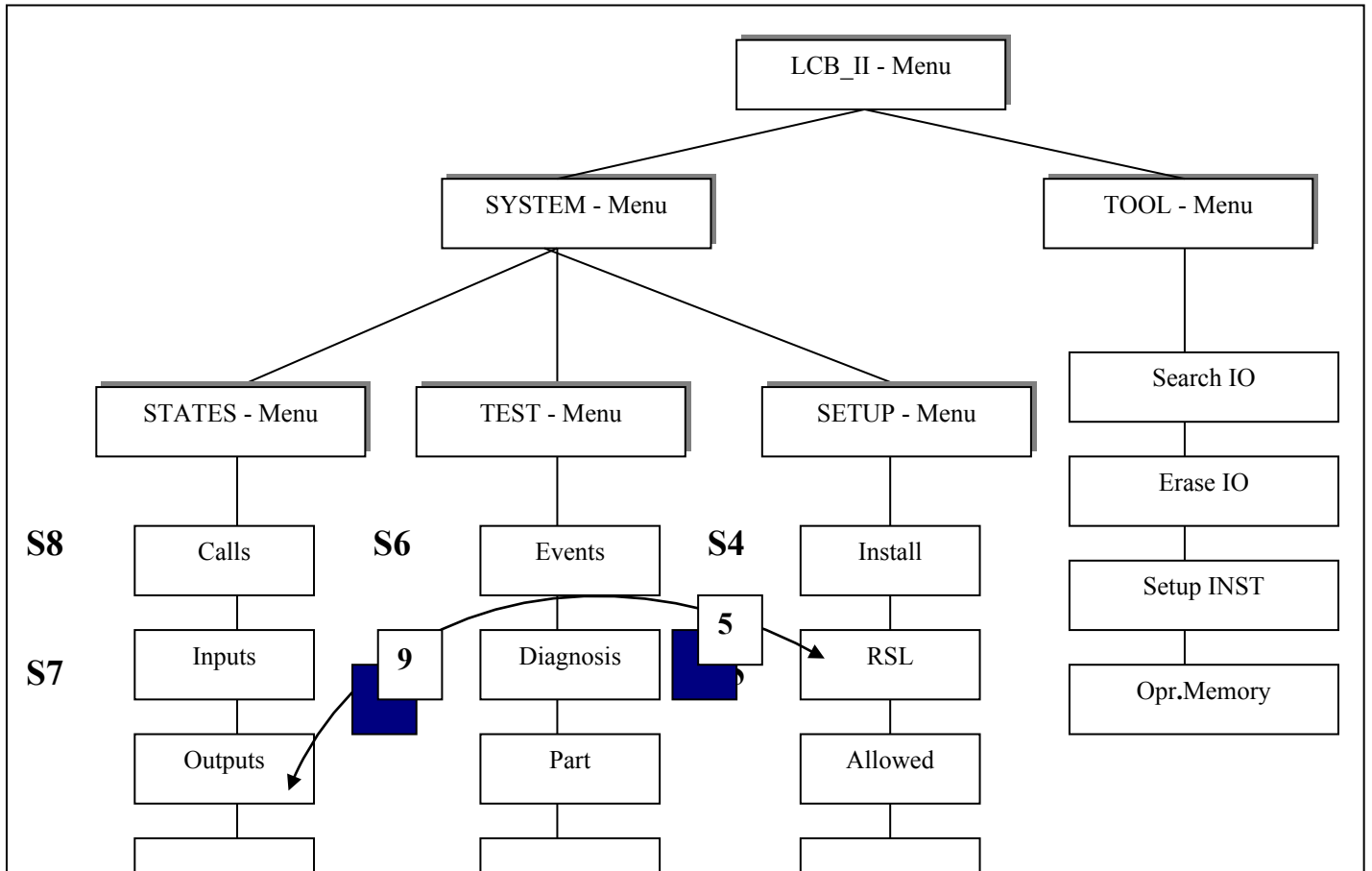
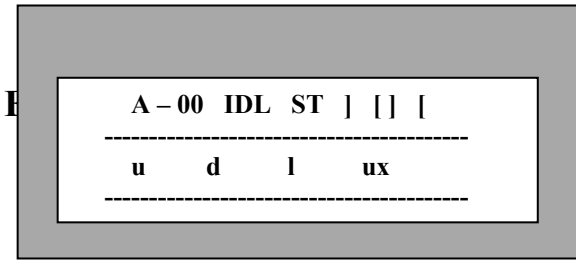

Figure 4 – 15: Standard Short Keys and Short Key S9

In Figure 4 – 15 you can see the function of Short Key S9.

In this example the function **STATUS / Outputs** is set to the **Short Key S9** function. Now S9 is acting like a Standard Short Key.

In Figure 4 – 15 the current position is **SETUP / RSL**. Now you can call function **STATUS / Output** with Short Key S9.



Function **STATUS / Output** (see chapter: 5.1.4)

Should be set as a Short Key function:

First you have to call **STATUS / Output**

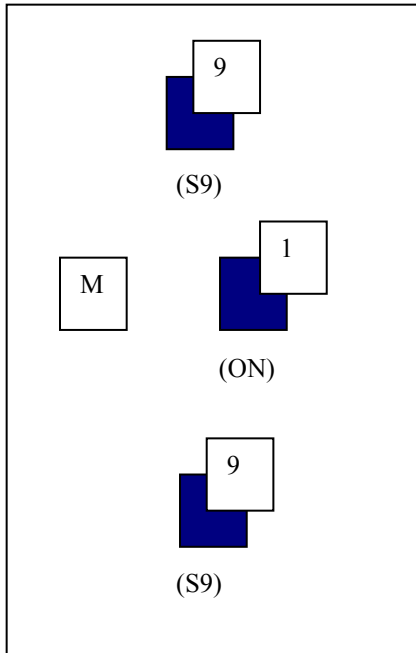

- Short Key S9: Position STATUS / Output is set to the Short Key S9 function

- Key **MODULE** and Shift Key **ON**:
The status of Store Key **S9** is displayed on the **LCB_II – Menu**.

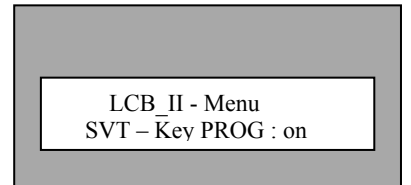

notice :

- Short Key **S9** and **LCB_II – Menu**:
Reset of Short Key **S9**.

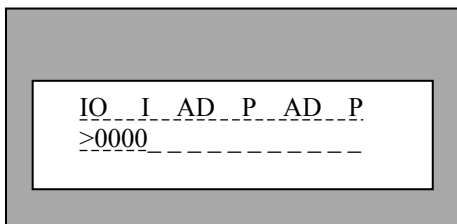
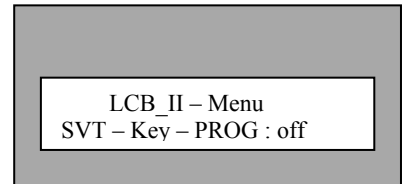

Now you can toggle between any function

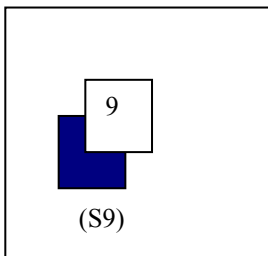

- Short Key **S9**: Call of function **STATUS / Output**.

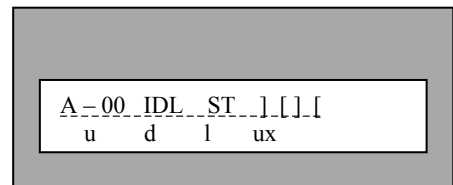

Service Tool Functions

5 Service Tool Functions

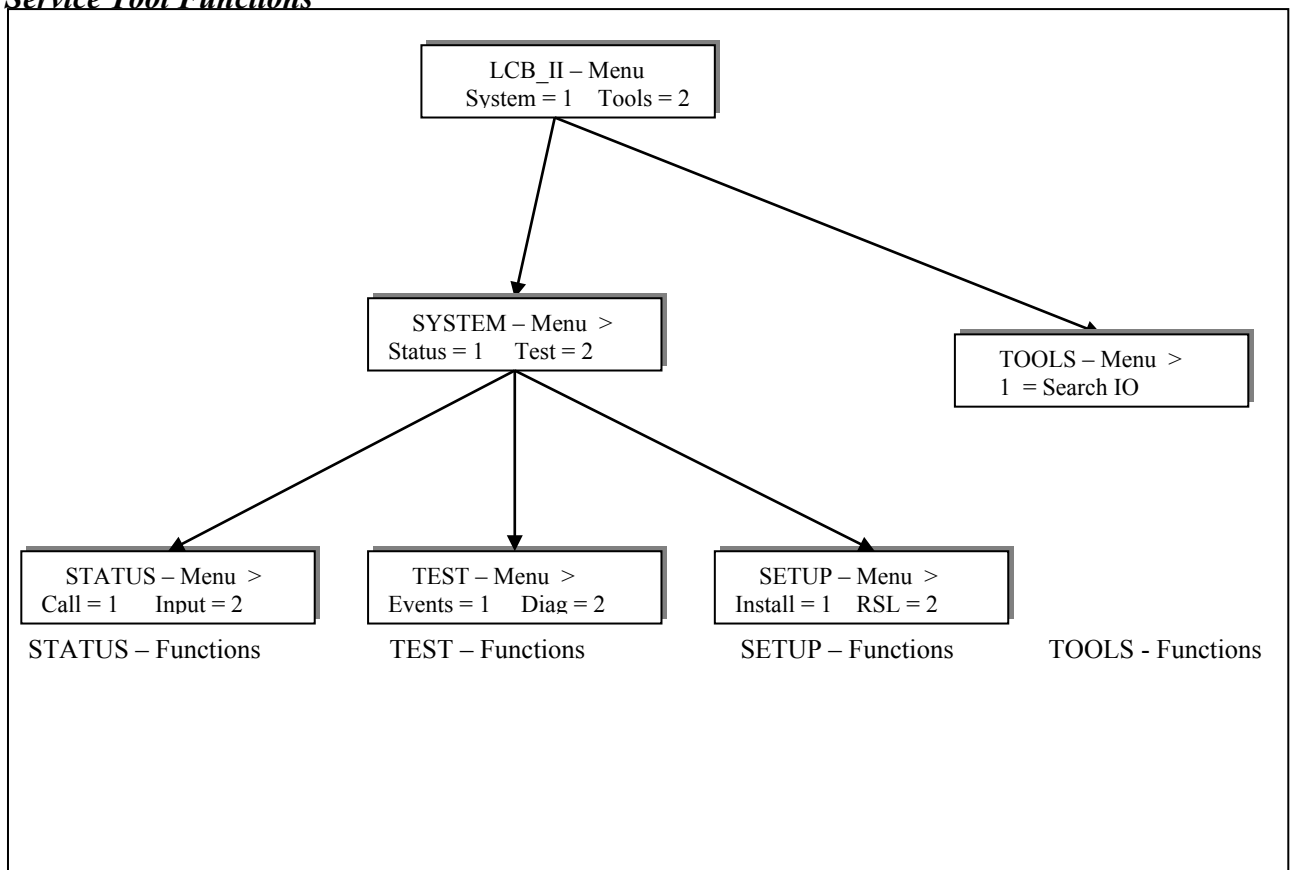

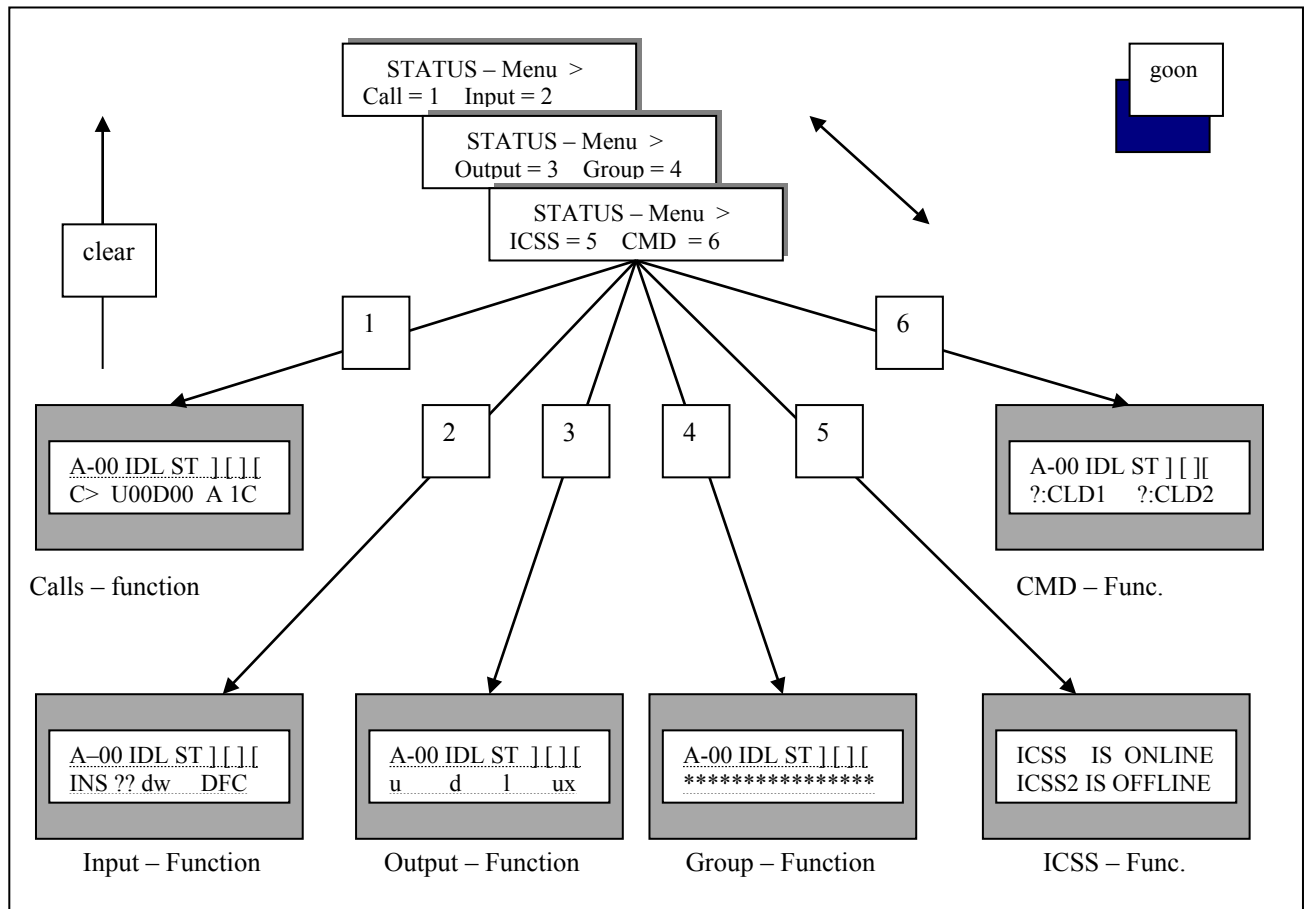
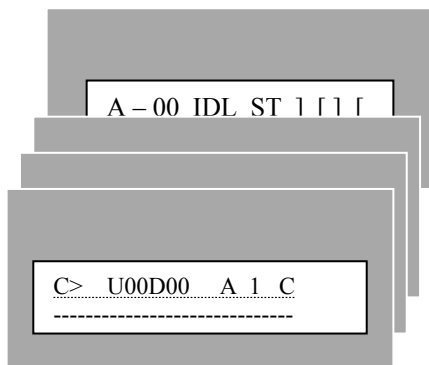

Figure 5 – 2 : STATUS – Functions



Following all the STATUS – functions are explained. The Calls, Input, Output, Group, ICSS and CMD functions control the elevator calls and monitor the software system I/O 's.

- The first row always displays the Software Status. It gives information about
- the car identifier in group
 - the direction of the moving cabin.
 - the current position.
 - the Operational Control software State, and
 - the Front and Rear Door State.

Please find in chapter 5.1.1 the exact description of

The Software Status Display (Row one)

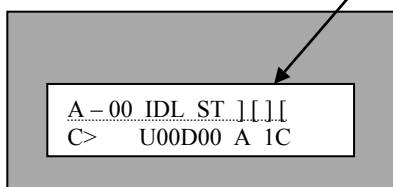
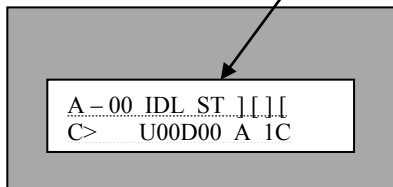
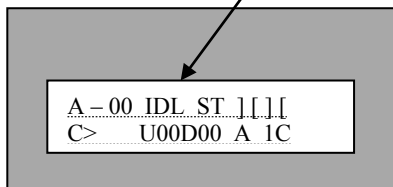
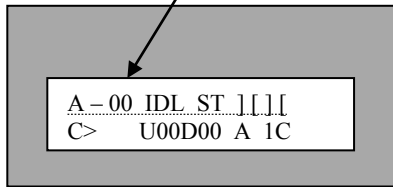
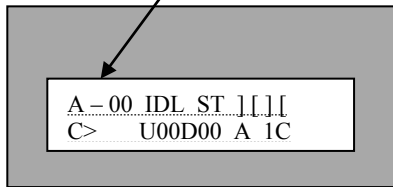
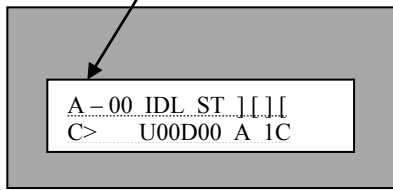

Car identifier	Description
A	First car of group / Simplex
B	second car in group
C	third car in group

Direction	Description
—	stop / direction not defined
U	car is moving in UP direction
D	car is moving in DOWN direction

Position	Description
00	actual level (level 0)
**	position not defined

OCSS mode	Description
IDL	current OCSS – mode (Idle) see document: Service Tool Reference List / Operation Modes

MCSS status	Description
ST	current MCSS – state (Stop) See document: Service Tool Reference List / Motion States

Doors states
][][

Description
front / rear door state:
][for Closed [] for Open
<> for Opening >< for Closing
** for door state not defined

```
A - 00 INS IN ][ ][  
C> U00D00 A 1C
```

In additional a blinking Event Message will be displayed during Software Status Display if one of the following events occurs and The elevator is blocked.

Examples:

```
A - 00 > TCI - LOCK !  
C> U00D00 A 1C
```

Event Message
>TCI - LOCK ! Leave Top of Car ' function on
>LS-FAULT ! 1LS / 2LS check negative
>start DCS ! Door Check Sequence not opr. yet
>ACS is on ! Anti Creeping Switch is operated
>1LS + 2LS ! 1LS and 2LS is operated

(see document: Service Tool Reference List / Event Messages)

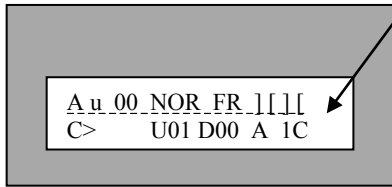
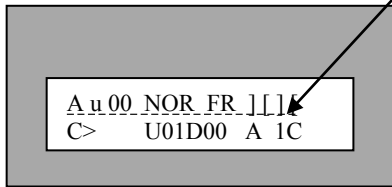
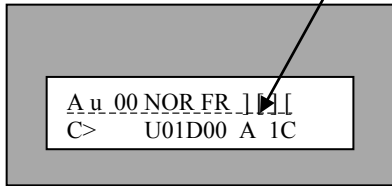
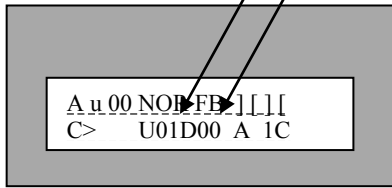

Call Demands

1)	01	number of UP-Call demands
2)	00	number of DOWN-Call dements

Load Status

A	ANS load
F	full load
P	peak load
O	overload
D	default load

Cars Available In Group

1-3	number of cars available in group
-----	-----------------------------------

C	Power Supply
E	Normal power supply
E	Emergency power supply

M-1-1-2

Input S7

5.1.3 Input – Function

Key Sequence

Short Key

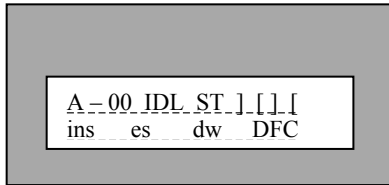

In **Figure 5-5** you can see the display of function **Input**.

The first row display the **Software Status** (see: 5.1.1).

Figure 5-5: Input – Function

The second row monitors the **System Inputs**

- Lower case letters of the input name stands for 'Function = OFF' and upper case letters for 'function = ON'
- Up to four signals are displayed in one row .you can skip to the next / previous group with **Key GOON** / **GOBACK**.
- Each group is assigned to a functional block. Both can be displayed with Shift Key ENTER.

Please refer to the manual for more details (see: 5.1.1)

The diagram is enclosed in a large rectangular frame. On the left side, there are three small boxes: the top one contains 'goon', the middle one contains '2', and the bottom one contains '3'. Below the 'goon' box is a blue L-shaped icon with the text '(GOBACK)' underneath. Below the '2' and '3' boxes are blue L-shaped icons with the text '(UP)' and '(DOWN)' respectively. On the right side, there is a text block: '- Key GOON / Shift Key GOBACK: Skip to the next / previous group of the System Inputs.' Below this is a screenshot of the display window showing 'A-00 IDL ST _ [] []' and 'md aes'. Below that is another text block: '- Shift Key UP / Shift Key DOWN: <toggle keys> Row one: Display of the functional block and the current group.' At the bottom right, there is a large grey rectangular area. Below the text block, there is a list: 'Block :System' and 'Group 1 :Safety Chain'.

以上内容仅为本文档的试下载部分，为可阅读页数的一半内容。如要下载或阅读全文，请访问：

<https://d.book118.com/598115055125006075>