

TEST REPORT

Product: Li-ion Battery

Model no.: 18650(Other models see page 5)

Trade Mark: Yinkai Power

Report No.: TCT141128E002

Issued Date: Dec. 01, 2014

Issued for:

Shenzhen Yinkai Power Technology Co., Ltd.

The 4th floor, 4building, Jinli industrial park, Jinniu west road Pingshan new district shenzhen, China

Issued By:

Shenzhen TCT Testing Technology Co., Ltd.

1F, Building 1, Yibaolai Industrial Park, Qiaotou Village, Fuyong Town, Baoan District, Shenzhen, Guangdong, China

TEL: +86-755-27673339

FAX: +86-755-27673332

Note: This report shall not be reproduced except in full, without the written approval of Shenzhen TCT Testing Technology Co., Ltd. This document may be altered or revised by Shenzhen TCT Testing Technology Co., Ltd. personnel only, and shall be noted in the revision section of the document.

The test results in the report only apply to the tested sample.

TABLE OF CONTENTS

1. TEST CERTIFICATION 3

2. TEST RESULT SUMMARY 4

3. EUT DESCRIPTION 5

4. TEST METHODOLOGY 6

 4.1. DECISION OF FINAL TEST MODE 6

 4.2. EUT SYSTEM OPERATION 6

5. SETUP OF EQUIPMENT UNDER TEST 7

 5.1. DESCRIPTION OF SUPPORT UNITS 7

 5.2. CONFIGURATION OF SYSTEM UNDER TEST 7

6. FACILITIES AND ACCREDITATIONS 8

 6.1. FACILITIES 8

 6.2. MEASUREMENT UNCERTAINTY 8

7. EMISSION TEST 9

 7.1. CONDUCTED EMISSION AT MAINS TERMINALS 9

 7.2. DISCONTINUOUS DISTURBANCE 11

 7.3. CONDUCTED EMISSION AT TELECOMMUNICATION/NETWORK PORT 13

 7.4. RADIATED EMISSION 15

 7.5. HARMONIC CURRENT EMISSIONS 20

 7.6. FLICKER AND VOLTAGE FLUCTUATION 21

8. IMMUNITY TEST 23

 8.1. GENERAL PERFORMANCE CRITERIA DESCRIPTION 23

 8.2. ELECTROSTATIC DISCHARGE (ESD) 24

 8.3. RADIO-FREQUENCY ELECTROMAGNETIC FIELD AMPLITUDE MODULATED (RS) 27

 8.4. ELECTRICAL FAST TRANSIENT (EFT) 30

 8.5. SURGES 33

 8.6. RADIO-FREQUENCY CONTINUOUS CONDUCTED (CS) 35

 8.7. POWER-FREQUENCY MAGNETIC FIELD (PFMF) 37

 8.8. VOLTAGE DIP & VOLTAGE INTERRUPTIONS 39

9. PHOTOGRAPHS OF TEST CONFIGURATION 41

10. PHOTOGRAPHS OF EUT 42

1. Test Certification

Product:	Li-ion Battery
Model no.:	18650 (Other models see page 5)
Applicant:	Shenzhen Yinkai Power Technology Co., Ltd.
Address:	The 4th floor, 4building, Jinli industrial park, Jinniu west road Pingshan new district shenzhen, China
Manufacturer:	Shenzhen Yinkai Power Technology Co., Ltd.
Address:	The 4th floor, 4building, Jinli industrial park, Jinniu west road Pingshan new district shenzhen, China
Test Voltage:	DC 3.7 V
Date of Test:	Nov. 28, 2014~ Nov. 30, 2014
Applicable Standards:	EN 61000-6-3:2007 + A1:2011 + AC :2012 EN 61000-6-1:2007 EN 61000-3-2:2006 + A1:2009 + A2:2009 EN 61000-3-3:2013

Deviation from Applicable Standard

None

The above equipment has been tested by Shenzhen TCT Testing Technology Co., Ltd. and found compliance with the requirements set forth in the technical standards mentioned above. The results of testing in this report apply only to the product/system, which was tested. Other similar equipment will not necessarily produce the same results due to production tolerance and measurement uncertainties.

Tested By: Lee Liu
Lee Liu

Date: Dec. 01, 2014

Check By: Davis Zh
Davis Zh

Date: Dec. 01, 2014

Approved By: Tolson
Tolson

Date: Dec. 01, 2014



2. Test Result Summary

Emission		
Test Method	Item	Result
EN 61000-6-3: 2007 + A1:2011 + AC :2012	Conducted Emission (Mains Terminals)	N/A
	Click	N/A
	Conducted Emission (Telecommunication/Network ports)	N/A
	Radiated Emission	Pass
EN61000-3-2:2006 + A1:2009 + A2:2009	Harmonic Current Emissions	N/A
EN 61000-3-3:2013	Voltage Fluctuations & Flicker	N/A

Immunity (EN 61000-6-1:2007)		
Test Method	Item	Result
EN 61000-4-2:2009	Electrostatic Discharge (ESD)	Pass
EN 61000-4-3:2006 + A1:2008 + A2:2010	Radio-frequency Electromagnetic Field Amplitude Modulated (RS)	Pass
EN 61000-4-4:2012	Electrical Fast Transients (EFT)	N/A
EN 61000-4-5:2006	Surge	N/A
EN 61000-4-6:2014	Radio-frequency Continuous Conducted (CS)	N/A
EN 61000-4-8: 2010	Power-frequency Magnetic Fields (PFMF)	N/A
EN 61000-4-11:2004	Voltage Dips & Voltage Interruptions	N/A

Note:

1. Pass: Test item meets the requirement.
2. Fail: Test item does not meet the requirement.
3. N/A: Test case does not apply to the test object.
4. The test result judgment is decided by the limit of test standard.
5. The information of measurement uncertainty is available upon the customer's request.

3. EUT Description

Product Name:	Li-ion Battery
Model no.:	18650
Product Parameter:	DC 3.7 V, 2.2 AH
AC Mains	<input type="checkbox"/> Shielded <input type="checkbox"/> Unshielded, <input type="checkbox"/> Detachable <input type="checkbox"/> Un-detachable <input checked="" type="checkbox"/> No applicable <input type="checkbox"/> Length:
DC Line	<input type="checkbox"/> Shielded <input type="checkbox"/> Unshielded, <input type="checkbox"/> Detachable <input type="checkbox"/> Un-detachable <input checked="" type="checkbox"/> No applicable <input type="checkbox"/> Length:
Control Lines	<input type="checkbox"/> Shielded <input type="checkbox"/> Unshielded, <input type="checkbox"/> Detachable <input type="checkbox"/> Un-detachable <input checked="" type="checkbox"/> No applicable <input type="checkbox"/> Length:

Model List and Differences

No.	Model Number	Tested With
1	18650	<input checked="" type="checkbox"/>
Other models	YK18650-1800mAh, YK18650-2000mAh, YK18650-2200mAh, YK18650-2400mAh, YK18650-2500mAh, YK18650-2600mAh, YK18650-2800mAh, YK18650-3000mAh, YK10440-300mAh, YK14500-800mAh, YK16340-650mAh, YK17650-3000mAh, YK18500-1500mAh, YK18500-1100mAh, YK22650-3000mAh, YK26650-3000mAh, YK26650-3500mAh, YK26650-4000mAh, YK26650-5000mAh	<input type="checkbox"/>

Note: 18650 is tested model, other models are derivative models, The models are identical in circuit and PCB layout, only different on the model names, and power rating, So the test data of 18650 can represent the remaining models.

4. Test Methodology

4.1. Decision of Final Test Mode

The EUT was tested together with the thereafter additional components, and a configuration, which produced the worst emission levels, was selected and recorded in this report.

The following test mode(s) were assessed:

Test Mode
Mode 1: Discharging

4.2. EUT System Operation

1. Set up EUT with the support equipments.
2. Make sure the EUT work normally during the test.

5. Setup of Equipment under Test

5.1. Description of Support Units

The EUT has been tested as an independent unit together with other necessary accessories or support units. The following support units or accessories were used to form a representative test configuration during the tests.

Equipment	Model No.	Serial No.	FCC ID	Trade Name
/	/	/	/	/

Note:

- (1) All the equipment/cables were placed in the worst-case configuration to maximize the emission during the test.
- (2) Grounding was established in accordance with the manufacturer's requirements and conditions for the intended use.

5.2. Configuration Of System Under Test



(EUT: Li-ion Battery)

6. Facilities and Accreditations

6.1. Facilities

All measurement facilities used to collect the measurement data are located at TCT Lab. The sites are constructed in conformance with the requirements of ANSI C63.4 and CISPR Publication 22. All receiving equipment conforms to CISPR Publication 16-1, "Radio Interference Measuring Apparatus and Measurement Methods."

6.2. Measurement Uncertainty

Where relevant, the following measurement uncertainty levels have been estimated for tests performed on the EUT as specified in CISPR 16-4-2:

No.	Item	MU
1.	Temperature	$\pm 0.1^{\circ}\text{C}$
2.	Humidity	$\pm 1.0 \%$
3.	Spurious Emissions, Conducted	$\pm 3.70 \text{ dB}$
4.	All Emissions, Radiated	$\pm 4.50 \text{ dB}$

This uncertainty represents an expanded uncertainty expressed at approximately the 95 % confidence level using a coverage factor of $k=2$.

7. Emission Test

7.1. Conducted Emission at Mains Terminals

7.1.1. Test Specification

Test Requirement:	EN 61000-6-3
Test Method:	CISPR 22
Frequency Range:	150 kHz to 30 MHz

7.1.2. Limits

Frequency (MHz)	dB(uV)	
	Quasi-peak	Average
0.15 - 0.5	66 - 56	56 - 46
0.50 - 5.0	56	46
5.0 - 30.0	60	50

Note: Limits decrease linearly with the logarithm of the frequency.

7.1.3. Test Instruments

Conducted Emission Shielding Room Test Site (843)				
Equipment	Manufacturer	Model	Serial Number	Calibration Due
EMI Test Receiver	R&S	ESCS30	100139	Sep. 16, 2015
LISN	Schwarzbeck	NSLK 8126	8126453	Sep. 29, 2015

Note: The calibration interval of the above test instruments is 12 months and the calibrations are traceable to international system unit (SI).

7.1.4. Test Method

The AMN was placed 0.8 m from the boundary of the unit under test and bonded to a ground reference plane. This distance was between the closest points of the AMN and the EUT. All other units of the EUT and associated equipment was at least 0.8 m from the AMN. All power was connected to the system through Artificial Mains Network (AMN). Conducted voltage measurements on mains lines were made at the output of the AMN.

7.1.5. Block Diagram of Test Setup

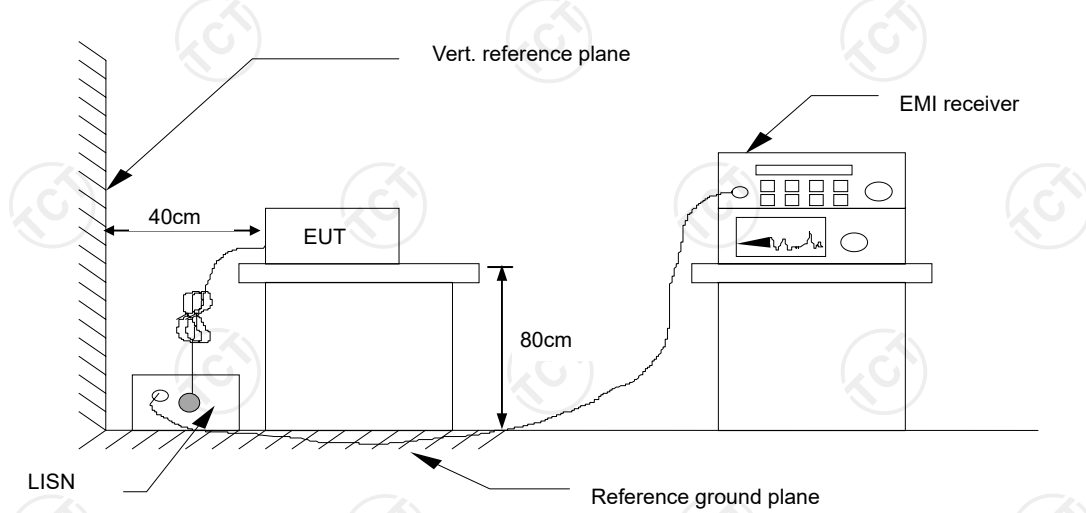

For the actual test configuration, please refer to the related item – Photographs of the Test Configuration.

7.1.6. Test Results

Note: This test isn't applicable because the EUT doesn't have relative function.

以上内容仅为本文档的试下载部分，为可阅读页数的一半内容。如要下载或阅读全文，请访问：<https://d.book118.com/696042105043010211>