

**OV7640 Color CMOS VGA (640 x 480) CAMERACHIP™
OV7141 B&W CMOS VGA (640 x 480) CAMERACHIP™**

General Description

The OV7640 (color) and OV7141 (black and white) CAMERACHIPS™ are low voltage CMOS image sensors that provide the full functionality of a single-chip VGA (640 x 480) camera and image processor in a small footprint package. The OV7640/OV7141 provides full-frame, sub-sampled or windowed 8-bit images in a wide range of formats, controlled through OmniVision's Serial Camera Control Bus (SCCB) interface.

This product family has an image array capable of operating at up to 30 frames per second (fps) with complete user control over image quality, formatting and output data transfer. All required image processing functions, including exposure control, gamma, white balance, color saturation, hue control and more, are also programmable through the SCCB interface. In addition, OmniVision CAMERACHIPS use proprietary sensor technology to improve image quality by reducing or eliminating common lighting/electrical sources of image contamination such as fixed pattern noise, smearing, blooming, etc. to produce a clean, fully stable color image.

Features

- High sensitivity for low-light operation
- 2.5V operating voltage for embedded portable applications
- Standard Serial Camera Control Bus (SCCB) interface
- VGA, QVGA (sub-sampled) and Windowed outputs with Raw RGB, RGB (GRB 4:2:2), YUV (4:2:2) and YCbCr (4:2:2) formats
- Automatic image control functions including: Automatic Exposure Control (AEC), Automatic Gain Control (AGC), Automatic White Balance (AWB), Automatic Brightness Control (ABC), Automatic Band Filter (ABF) for 60Hz noise and Automatic Black-Level Calibration (ABLC)
- Image quality controls including color saturation, hue, gamma, sharpness (edge enhancement), anti-blooming and zero smearing

Ordering Information

Product	Package
OV7640 (Color)	PLCC-28
OV7141 (B&W)	PLCC-28

Applications

- Cellular and Picture Phones
- Toys
- PC Multimedia

Key Specifications

	Array Size	640 x 480 (VGA)
Power Supply	Core	2.5VDC ± 10%
	Analog	2.5VDC ± 4%
	I/O	2.25V to 3.3V
Power Requirements	Active	40 mW (30 fps, including I/O power)
	Standby	30 µW
Temperature Range	Operation	10°C to 70°C
	Stable Image	0°C to 50°C
Output Formats (8-bit)		<ul style="list-style-type: none"> • YUV/YCbCr 4:2:2 • RGB 4:2:2 • Raw RGB Data
Lens Size		1/4"
Maximum Image Transfer Rate	VGA	30 fps
	QVGA	60 fps
Sensitivity	B&W	3.0 V/Lux sec
	Color	1.12 V/Lux sec
S/N Ratio		46 dB
Dynamic Range		62 dB
Scan Mode		Progressive/Interlaced
Maximum Exposure Interval		523 x t _{ROW}
Gamma Correction		0.45
Pixel Size		5.6 µm x 5.6 µm
Dark Current		30 mV/s
Well Capacity		60 Ke
Fixed Pattern Noise		< 0.03% of V _{PEAK-TO-PEAK}
Image Area		3.6 mm x 2.7 mm
Package Dimensions		11.43 mm x 11.43 mm

Figure 1 OV7640/OV7141 Pin Diagram

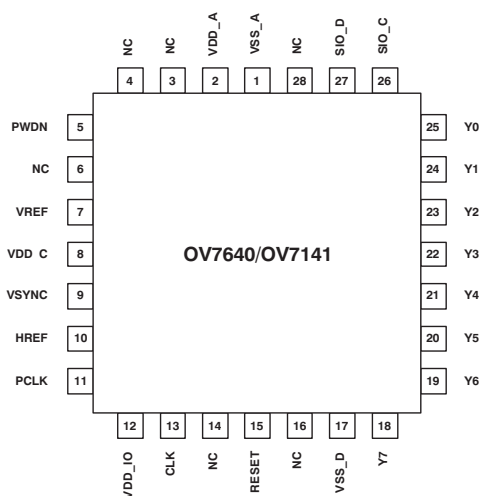

Functional Description

Figure 2 shows the functional block diagram of the OV7640/OV7141 image sensor. The OV7640/OV7141 includes:

- Image Sensor Array (640 x 480 resolution)
- Timing Generator
- Analog Processing Block
- A/D Converters
- Output Formatter
- Digital Video Port
- SCCB Interface

Figure 2 OV7640/OV7141 Functional Block Diagram

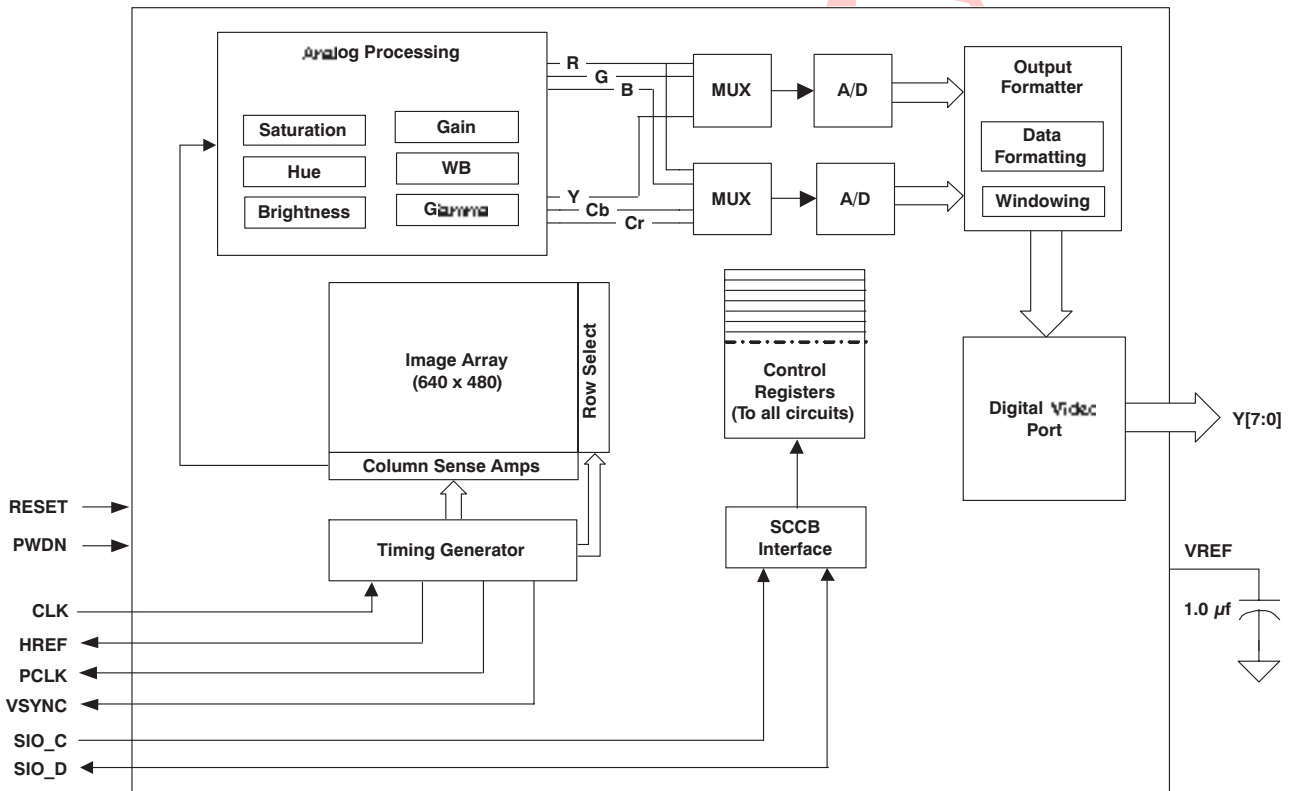
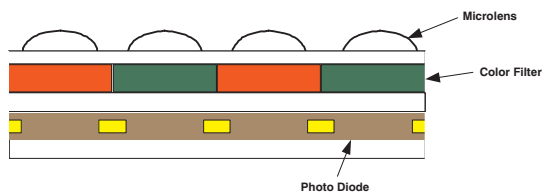

Image Sensor Array

The OV7640/OV7141 CAMERACHIPS has an active image array size of 640 columns x 480 rows (307,200 pixels). However, the full array contains 652 columns and 486 rows, with the extra 6 rows used for black-level calibration (“Optical Black”) and color interpolation information. [Figure 3](#) shows a cross-section of the image sensor array.

Figure 3 Image Sensor Array



Timing Generator

In general, the timing generator controls these functions:

- Array control and frame generation (VGA and QVGA outputs)
- Internal timing signal generation and distribution
- Frame rate timing
- Automatic Exposure Control (AEC)
- External timing outputs (VSYNC, HREF and PCLK)

Analog Processing Block

This block performs all analog image functions including:

- Automatic Gain Control (AGC)
- Automatic White Balance (AWB)
- Image quality controls including:
 - Color saturation
 - Hue
 - gamma
 - Sharpness (edge enhancement)
 - Anti-blooming
 - Zero smearing

A/D Converters

After the Analog Processing Block, the color channel data signal is fed to two 8-bit Analog-to-Digital (A/D) converters via the multiplexers, one for the Y/G channel and one shared by the CrCb/BR channels. These A/D converters operate at speeds up to 12MHz, and are fully synchronous to the pixel rate (actual conversion rate is related to the frame rate).

In addition to the A/D conversion, this block also has the following functions:

- Digital Black-Level Calibration (BLC)
- Optional U/V channel delay
- Additional A/D range controls

In general, the combination of the A/D Range Multiplier and A/D Range Control sets the A/D range and maximum value to allow the user to adjust the final image brightness as a function of the individual application.

Output Formatter

This block controls all output and data formatting required prior to sending the image out.

Digital Video Port

These two bits increase I_{OL} / I_{OH} drive current and can be adjusted as a function of the customer’s loading:

SCCB Interface

The Serial Camera Control Bus (SCCB) interface controls the CAMERACHIP operation. Refer to [OmniVision Technologies Serial Camera Control Bus \(SCCB\) Specification](#) for detailed usage of the serial control port.

Pin Description

Table 1 Pin Description

Pin Number	Name	Pin Type	Function/Description
01	VSS_A	Ground	Analog ground
02	VDD_A	V _{DD}	Analog VDD
03	NC	—	No connection
04	NC	—	No connection
05	PWDN	Input	Sets device to power down standby mode
06	NC	—	No connection
07	VREF	V _{REF}	Internal voltage reference (2.3V). Connect to ground through 1μF capacitor
08	VDD_C	V _{DD}	Core VDD
09	VSYNC	Output	Vertical sync output
10	HREF	Output	HREF output
11	PCLK	Output	Pixel clock output
12	VDD_IO	V _{DD}	I/O VDD
13	CLK	Input	External clock
14	NC	—	No connection
15	RESET	Input	Clears all registers and resets them to their default values.
16	NC	—	No connection
17	VSS_D	Ground	Digital ground
18	Y7	Output	Digital video output bit[7]
19	Y6	Output	Digital video output bit[6]
20	Y5	Output	Digital video output bit[5]
21	Y4	Output	Digital video output bit[4]
22	Y3	Output	Digital video output bit[3]
23	Y2	Output	Digital video output bit[2]
24	Y1	Output	Digital video output bit[1]
25	Y0	Output	Digital video output bit[0]
26	SIO_C	Input	SCCB serial interface clock
27	SIO_D	I/O	SCCB serial interface data I/O
28	NC	—	No connection

Electrical Characteristics

Table 2 Absolute Maximum Ratings

Ambient Storage Temperature		-40°C to +125°C
Supply Voltages (with respect to Ground)	V_{DD-A}	3V
	V_{DD-C}	3V
	V_{DD-IO}	4V
All Input/Output Voltages (with respect to Ground)		-0.3V to V _{DD-IO} +1V
Lead Temperature, Surface-mount process		+230°C
ESD Rating, Human Body model		2000V

NOTE: Exceeding the Absolute Maximum ratings shown above invalidates all AC and DC electrical specifications and may result in permanent device damage.

Table 3 DC Characteristics (0°C < T_A < 70°C)

Symbol	Parameter	Condition	Min	Typ	Max	Unit
V _{DD A}	DC supply voltage – Analog	—	2.40	2.5	2.60	V
V _{DD C}	DC supply voltage – Core	—	2.25	2.5	2.75	V
V _{DD IO}	DC supply voltage – I/O	—	2.25	—	3.3	V
I _{DDA}	Active (Operating) Current	See Note ^a		15		mA
I _{DDS SCCB}	Standby Current	See Note ^b		1		mA
I _{DDS PWDN}	Standby Current			10		μA
V _{IH}	Input voltage HIGH	CMOS	0.7 x V _{DD IO}			V
V _{IL}	Input voltage LOW				0.3 x V _{DD IO}	V
V _{OH}	Output voltage HIGH	CMOS (I _{OH} / I _{OL})	0.9 x V _{DD IO}			V
V _{OL}	Output voltage LOW				0.1 x V _{DD IO}	V
I _{OH}	Output current HIGH	See Note ^c	8			mA
I _{OL}	Output current LOW		15			mA
I _L	Input/Output Leakage	GND to V _{DD IO}			± 1	μA

- a. V_{DD-A} = V_{DD-C} = 2.5V, V_{DD-IO} = 3.0V
 I_{DDA} = Σ(I_{DD-IO} + I_{DD-C} + I_{DD-A}), f_{CLK} = 24MHz at 30 fps, no I/O loading
- b. V_{DD-A} = V_{DD-C} = 2.5V, V_{DD-IO} = 3.0V
 I_{DDS:SCCB} refers to a SCCB initiated Standby, while I_{DDS:PWDN} refers to a PWDN pin initiated Standby
- c. Standard Output Loading = 25pF, 1.2KΩ to 3V

以上内容仅为本文档的试下载部分，为可阅读页数的一半内容。如要下载或阅读全文，请访问：<https://d.book118.com/786140013123010142>