



RCU60
RCU61



RCU60.1
RCU61.1

Room Temperature Controllers for CAV and VAV systems

RCU60../61..

Modulating P-control
DC 0...10 V output for cooling
ON / OFF or PWM outputs AC 24 V for heating (RCU60 / 60.1)
Three-position output AC 24 V for heating (RCU61 / 61.1)
Operating modes: normal operation, energy saving and standby
Operating mode selector (RCU60.1 / 61.1)
Active DC 0...10 V input for setpoint shifting
Operating mode changeover input for remote control
Adjustable minimum limitation for cooling output
Operating voltage AC 24 V

Use

Control of the room temperature in individual rooms of ventilation or air conditioning plants that are heated or cooled. The RCU6... are especially suited for use in VAV systems with auxiliary heating in connection with VAV compact controllers type GLB181.1E / 3 and GDB181.1E / 3.

For the control of the following pieces for equipment:

- VAV compact controllers
- Valve actuators
- Air damper actuators



**RCU60
RCU61**



**RCU60.1
RCU61.1**

Room Temperature Controllers **RCU60../61..**

for CAV and VAV systems

Modulating P-control

DC 0...10 V output for cooling

ON / OFF or PWM outputs AC 24 V for heating (RCU60 / 60.1)

Three-position output AC 24 V for heating (RCU61 / 61.1)

Operating modes: normal operation, energy saving and standby

Operating mode selector (RCU60.1 / 61.1)

Active DC 0...10 V input for setpoint shifting

Operating mode changeover input for remote control

Adjustable minimum limitation for cooling output

Operating voltage AC 24 V

Use

Control of the room temperature in individual rooms of ventilation or air conditioning plants that are heated or cooled. The RCU6... are especially suited for use in VAV systems with auxiliary heating in connection with VAV compact controllers type GLB181.1E / 3 and GDB181.1E / 3.

For the control of the following pieces of equipment:

- VAV compact controllers
- Valve actuators
- Air damper actuators

The controller acquires the room temperature with its integrated sensor and maintains the setpoint by delivering control commands. The proportional band or the switching differential can be 1 or 4 Kelvin in heating mode and 0.5 or 2 Kelvin in cooling mode (selectable with DIP switch no. 4).

Function diagram
"Heating-cooling" with minimum limitation cooling

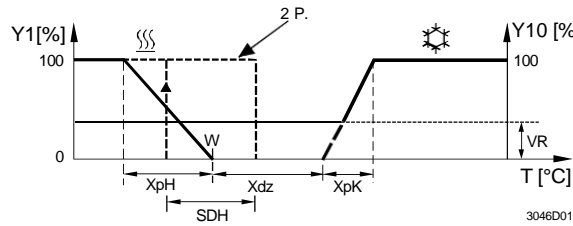

- T Room or return air temperature
- Y1, Y10 Output percentage
- W Room temperature setpoint
- Xdz Dead band
- XpH Proportional band heating
- XpK Proportional band cooling
- SDH Switching differential heating
- VR 0-100 % min. limitation of cooling output
- 2 P. 2-position output

Function diagram
"Heating-cooling" with minimum limitation cooling

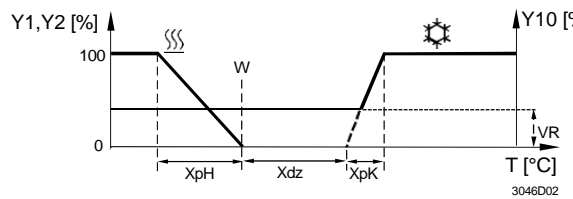

- T Room or return air temperature
- Y1, Y2, Y10 Output percentage
- W Room temperature setpoint
- Xdz Dead band
- XpH Proportional band heating
- XpK Proportional band cooling
- VR 0-100 % min. limitation cooling output

Minimum limitation of cooling signal

Using the potentiometer at the rear of the controller, the cooling signal output can be limited to a minimum value of between 0 and 100 %. This function can be used to ensure a minimum supply air volume. When used in connection with a VAV controller, this setting must be taken into account.

Pulse width modulation (RCU60...)

If "Pulse width modulation" (PWM) for the heating output is selected with DIP switch no. 6, the output is switched on and off for a certain period of time, proportional to the calculated manipulated variable and following an interval. The interval of the PWM actuating signal can be selected and is 90 or 240 seconds (DIP switch no. 7)

Note

When used in connection with thermic actuators, the selected interval should be 240 seconds. When using electric heaters, it should be 90 seconds.

Caution

When used in connection with electric valve actuators, DIP switch no. 6 must be set to ON for two-position control with ON / OFF control commands.

PWM actuating signals may never be used for driving electric actuators!

Three-position control signal (RCU61/61.1)

Outputs Y1 = opening, Y2 = closing and G = power supply are used to drive three-position actuators with a maximum running time of 150 seconds from the fully closed to the fully open position.

When commissioning the controller, an opening signal of 200 seconds is delivered, followed by a closing signal of 200 seconds to ensure the actuator will be fully closed. When the actuator has reached the position calculated by the controller, a waiting time of 30 seconds is observed in order to stabilize the outputs.

The control outputs carry AC 24 V.



Setpoint shifting

Signal input B1-M is used for outside temperature compensation. Using a DC 0... 10 V signal, the setpoint can be shifted by + / - 12.5 Kelvin. The neutral position is at DC 5 V and means no setpoint shift.

The controller acquires the room temperature with its integrated sensor and maintains the setpoint by delivering control commands. The proportional band or the switching differential can be 1 or 4 Kelvin in heating mode and 0.5 or 2 Kelvin in cooling mode (selectable with DIP switch no. 4).

**Function diagram
“Heating-cooling“
with minimum
limitation cooling
RCU60 and 60.1**

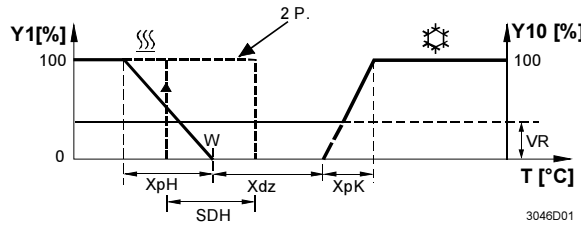

- T Room or return air temperature
- Y1, Y10 Output percentage
- W Room temperature setpoint
- Xdz Dead band
- XpH Proportional band heating
- XpK Proportional band cooling
- SDH Switching differential heating
- VR 0-100 % min. limitation of cooling output
- 2 P. 2-position output

**Function diagram
“Heating-cooling“
with minimum
limitation cooling
RCU61 and 61.1**

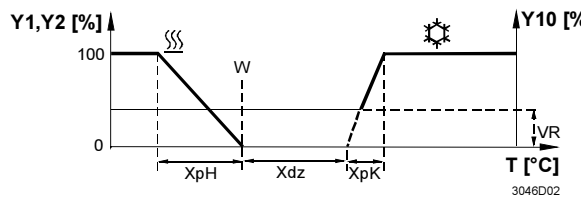

- T Room or return air temperature
- Y1,2 Y10 Output percentage
- W Room temperature setpoint
- Xdz Dead band
- XpH Proportional band heating
- XpK Proportional band cooling
- VR 0-100 % min. limitation cooling output

**Minimum limitation of
cooling signal**

Using the potentiometer at the rear of the controller, the cooling signal output can be limited to a minimum value of between 0 and 100 %. This function can be used to ensure a minimum supply air volume. When used in connection with a VAV controller, this setting must be taken into account.

**Pulse width
modulation (RCU60...)**

If “Pulse width modulation” (PWM) for the heating output is selected with DIP switch no. 6, the output is switched on and off for a certain period of time, proportional to the calculated manipulated variable and following an interval. The interval of the PWM actuating signal can be selected and is 90 or 240 seconds (DIP switch no. 7)

Note

When used in connection with thermic actuators, the selected interval should be 240 seconds. When using electric heaters, it should be 90 seconds.

Caution

When used in connection with electric valve actuators, DIP switch no. 6 must be set to ON for two-position control with ON / OFF control commands.

PWM actuating signals may never be used for driving electric actuators!

**Three-position
control signal
(RCU61/61.1)**

Outputs Y1 = opening, Y2 = closing and G = power supply are used to drive three-position actuators with a maximum running time of 150 seconds from the fully closed to the fully open position.

When commissioning the controller, an opening signal of 200 seconds is delivered, followed by a closing signal of 200 seconds to ensure the actuator will be fully closed. When the actuator has reached the position calculated by the controller, a waiting time of 30 seconds is observed in order to stabilize the outputs.



Setpoint shifting

The control outputs carry AC 24 V.

Signal input B1-M is used for outside temperature compensation. Using a DC 0... 10 V signal, the setpoint can be shifted by + / - 12.5 Kelvin. The neutral position is at DC 5 V and means no setpoint shift.

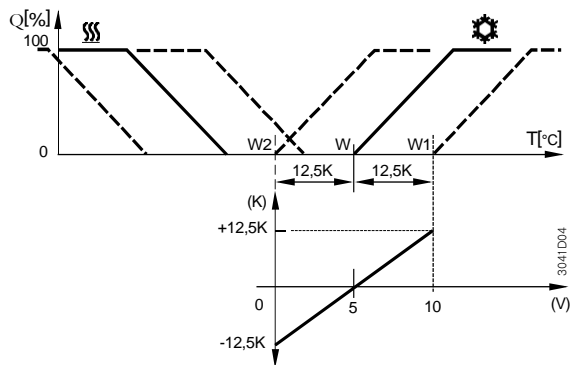

- W Original setpoint
- W1 Highest setpoint at 10 V input
- W2 Lowest setpoint t at 0 V input
- (K) Total setpoint shift
- (V) Input voltage



The setpoint shift is limited within the range of the unit of 8 °C (frost protection) to 30 °C.

Energy saver

The room temperature setpoint can be limited in increments of 1 Kelvin by making use of the minimum and maximum limitation facility. Arbitrary setpoint readjustments can thus be prevented.

Operating modes

The following operating modes are available:

Normal operation

Normal operation is activated when the operating mode selector is set to “☀” (RCU 60.1 and RCU61.1) and the external operating mode changeover switch is not activated. In normal operation, the controller maintains the adjusted setpoint.

Frost protection mode

Frost protection mode can be activated either by

- manually switching to standby “☾” (RCU60.1 and RCU61.1) and DIP-Switch No.3 “ is set to off.
- activating the external operating mode changeover switch, provided DIP switch no. 1 is set to OFF

If the room temperature falls below 8 °C, the controller will automatically switch to frost protection mode. In that case, the heating valve opens and the room temperature is maintained at a setpoint of 8 °C. The setpoint adjusted by the user will then be ignored.

Energy saving mode

Energy saving mode can be activated either by

- manually switching to energy saving “☾” (RCU60.1 and RCU61.1)
- activating the external operating mode changeover switch, provided DIP switch no. 1 is set to ON

In energy saving mode, the setpoint of heating is 16 °C and the setpoint of cooling 28 °C, independent of the position of the setpoint knob.

Operating mode changeover switch

A changeover switch can be connected to status input D1–GND. When the switch closes its contact (caused by an open window, for instance), the operating mode will change from normal operation or standby to energy saving mode (provided DIP switch no. 1 is set to ON), or from normal operation or energy saving mode to standby (provided DIP switch no. 1 is set to OFF).

The operating action of the switch (N.C. or N.O.) can be selected.

Type summary

Type reference	Features
RCU60	With ON / OFF or PWM signal for heating, without operating mode selector
RCU60.1	With ON / OFF or PWM signal for heating, with operating mode selector
RCU61	With three-position signal for heating, without operating mode selector
RCU61.1	With three-position signal for heating, with operating mode selector

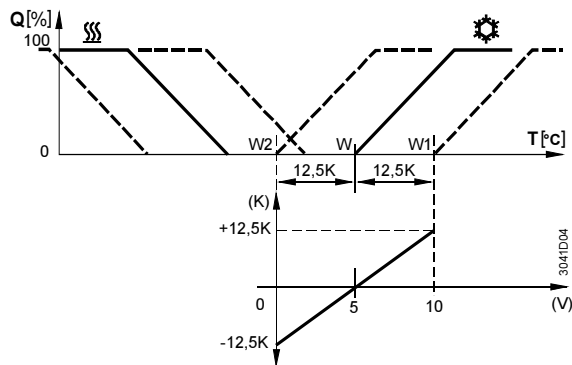

- W Original setpoint
- W1 Highest setpoint at 10 V input
- W2 Lowest setpoint t at 0 V input
- (K) Total setpoint shift
- (V) Input voltage



The setpoint shift is limited within the range of the unit of 8 °C (frost protection) to 30 °C.

Energy saver

The room temperature setpoint can be limited in increments of 1 Kelvin by making use of the minimum and maximum limitation facility. Arbitrary setpoint readjustments can thus be prevented.

Operating modes

The following operating modes are available:

Normal operation

Normal operation is activated when the operating mode selector is set to “☀” (RCU 60.1 and RCU61.1) and the external operating mode changeover switch is not activated. In normal operation, the controller maintains the adjusted setpoint.

Frost protection mode

Frost protection mode can be activated either by

- manually switching to standby “☾” (RCU60.1 and RCU61.1) and DIP-Switch No.3 is set to off.
- activating the external operating mode changeover switch, provided DIP switch no. 1 is set to OFF

If the room temperature falls below 8 °C, the controller will automatically switch to frost protection mode. In that case, the heating valve opens and the room temperature is maintained at a setpoint of 8 °C. The setpoint adjusted by the user will then be ignored.

Energy saving mode

Energy saving mode can be activated either by

- manually switching to energy saving “☾” (RCU60.1 and RCU61.1)
- activating the external operating mode changeover switch, provided DIP switch no. 1 is set to ON

In energy saving mode, the setpoint of heating is 16 °C and the setpoint of cooling 28 °C, independent of the position of the setpoint knob.

Operating mode changeover switch

A changeover switch can be connected to status input D1–GND. When the switch closes its contact (caused by an open window, for instance), the operating mode will change from normal operation or standby to energy saving mode (provided DIP switch no. 1 is set to ON), or from normal operation or energy saving mode to standby (provided DIP switch no. 1 is set to OFF).

The operating action of the switch (N.C. or N.O.) can be selected.

Type summary

Type reference	Features
RCU60	With ON / OFF or PWM signal for heating, without operating mode selector
RCU60.1	With ON / OFF or PWM signal for heating, with operating mode selector
RCU61	With three-position signal for heating, without operating mode selector
RCU61.1	With three-position signal for heating, with operating mode selector

Ordering

When ordering, please give name and type reference, e.g. room temperature controller RCU60.

Valve and air dampers actuators are to be ordered as separate items.

Equipment combinations

Type of unit	Type reference	Data sheet
VAC compact controllers	GDB181.1E/3 GLB181.1E/3	3544
Three-position valve actuator		
Motoric actuator (radiator valve)	SSA81...	4893
Motoric actuator (small valve 2,5 mm)	SSP81...	4864
Motoric actuator (small valve 5,5 mm)	SSB81...	4891
Motoric actuator (valve 5,5 mm)	SSC81...	4895
Motoric actuator (valve 5,5 mm)	SQS85...	4573
Two-position valve actuator		
Motoric on/off actuator (not suitable for PWM mode)	SFA71...	4863
Thermal actuator (radiator valve)	STA71...	4877
Thermal actuator (small valve 2,5 mm)	STP71...	4878
DC 0...10 V valve actuators		
Motoric actuator (radiator valve)	SSA61...	4893
Motoric actuator (small valve 2,5 mm)	SSP61...	4864
Motoric actuator (small valve 5,5 mm)	SSB61...	4891
Motoric actuator (valve 5,5 mm)	SSC61...	4895
Motoric actuator (valve 5,5 mm)	SQS65...	4573
Air damper actuators	GDB161.1E GLB161.1E GCA161.1E GBB161.1E GIB161.1E	4634 4634 4613 4626 4626

Mechanical design

The unit consists of two parts:

- A plastic housing which accommodates the electronics, the operating elements and the built-in room temperature sensor
- A mounting base

The housing engages in the mounting base and snaps on.

The base carries the screw terminals. The DIP switches are located at the rear of the unit.

Ordering

When ordering, please give name and type reference, e.g. room temperature controller RCU60.

Valve and air dampers actuators are to be ordered as separate items.

Equipment combinations

Type of unit	Type reference	Data sheet
VAC compact controllers	GDB181.1E/3 GLB181.1E/3	3544
Three-position valve actuator		
Motoric actuator (radiator valve)	SSA81...	4893
Motoric actuator (small valve 2,5 mm)	SSP81...	4864
Motoric actuator (small valve 5,5 mm)	SSB81...	4891
Motoric actuator (valve 5,5 mm)	SSC81...	4895
Motoric actuator (valve 5,5 mm)	SQS85...	4573
Two-position valve actuator		
Motoric on/off actuator (not suitable for PWM mode)	SFA71...	4863
Thermal actuator (radiator valve)	STA71...	4877
Thermal actuator (small valve 2,5 mm)	STP71...	4878
DC 0...10 V valve actuators		
Motoric actuator (radiator valve)	SSA61...	4893
Motoric actuator (small valve 2,5 mm)	SSP61...	4864
Motoric actuator (small valve 5,5 mm)	SSB61...	4891
Motoric actuator (valve 5,5 mm)	SSC61...	4895
Motoric actuator (valve 5,5 mm)	SQS65...	4573
Air damper actuators	GDB161.1E GLB161.1E GCA161.1E GBB161.1E GIB161.1E	4634 4634 4613 4626 4626

Mechanical design

The unit consists of two parts:

- A plastic housing which accommodates the electronics, the operating elements and the built-in room temperature sensor
- A mounting base

The housing engages in the mounting base and snaps on.

The base carries the screw terminals. The DIP switches are located at the rear of the unit.

Operating and setting elements

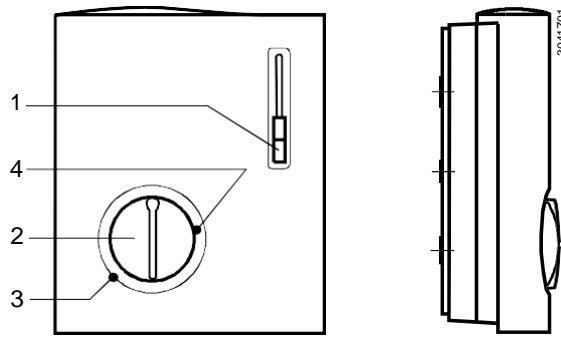

Legend

- 1 Operating mode selector (RCU60.1 / 61.1)
(normal operation, energy saving mode and standby)
- 2 Room temperature setpoint knob
- 3 Setting facility for minimum setpoint limitation (in increments of 1 Kelvin)
- 4 Setting facility for maximum setpoint limitation (in increments of 1 Kelvin)

Set of DIP switches of RCU60 and RCU60.1

DIP switch no.	Meaning	Position ON	Position OFF
1	Operating mode changeover via external switch	Changeover from normal operation or standby to energy saving mode	Changeover from normal operation or energy saving to standby ¹⁾
2	Operating action of switch for external operating mode changeover	Changeover activated when contact of switch is closed (N.O.) ¹⁾	Changeover activated when contact of switch is open (N.C.)
3	Standby	OFF	Frost protection mode (heating output ON at a setpoint of 8 °C) ¹⁾
4	Switching differential or P-band	1 K in heating mode ¹⁾ 0.5 K in cooling mode ¹⁾	4 K in heating mode 2 K in cooling mode
5	Dead zone (Xdz)	2 K ¹⁾	5 K
6	Signal output Y1 (heating)	ON / OFF ¹⁾	PWM
7	PWM signal interval for output Y1 (heating)	240 s ¹⁾	90 s
8	Cooling output signal in energy saving mode	Active	Inactive ¹⁾

1) Factory setting

Set of DIP switches of RCU61.0 and RCU61.1

DIP switch no.	Meaning	Position ON	Position OFF
1	Operating mode changeover via external switch	Changeover from normal operation or standby to energy saving mode	Changeover from normal operation or energy saving to standby ¹⁾
2	Operating action of switch for external operating mode changeover	Changeover activated when contact of switch is closed (N.O.) ¹⁾	Changeover activated when contact of switch is open (N.C.)
3	Standby	OFF	Frost protection mode (heating output ON at a setpoint of 8 °C) ¹⁾
4	P-band	1 K in heating mode 0.5 K in cooling mode	4 K in heating mode ¹⁾ 2 K in cooling mode ¹⁾
5	Dead zone (Xdz)	2 K ¹⁾	5 K
6	Cooling output signal in energy saving mode	Active	Inactive ¹⁾

1) Factory setting

Operating and setting elements

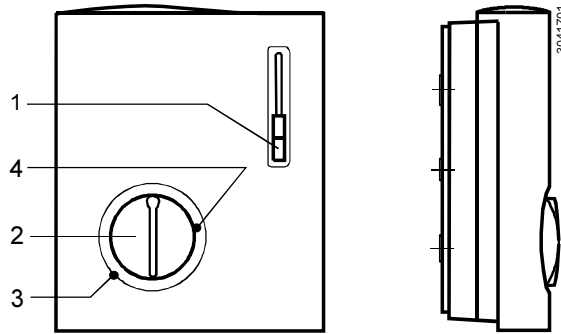

Legend

- 1 Operating mode selector (RCU60.1 / 61.1)
(normal operation, energy saving mode and standby)
- 2 Room temperature setpoint knob
- 3 Setting facility for minimum setpoint limitation (in increments of 1 Kelvin)
- 4 Setting facility for maximum setpoint limitation (in increments of 1 Kelvin)

Set of DIP switches of RCU60 and RCU60.1

DIP switch no.	Meaning	Position ON	Position OFF
1	Operating mode changeover via external switch	Changeover from normal operation or standby to energy saving mode	Changeover from normal operation or energy saving to standby ¹⁾
2	Operating action of switch for external operating mode changeover	Changeover activated when contact of switch is closed (N.O.) ¹⁾	Changeover activated when contact of switch is open (N.C.)
3	Standby	OFF	Frost protection mode (heating output ON at a setpoint of 8 °C) ¹⁾
4	Switching differential or P-band	1 K in heating mode ¹⁾ 0.5 K in cooling mode ¹⁾	4 K in heating mode 2 K in cooling mode
5	Dead zone (Xdz)	2 K ¹⁾	5 K
6	Signal output Y1 (heating)	ON / OFF ¹⁾	PWM
7	PWM signal interval for output Y1 (heating)	240 s ¹⁾	90 s
8	Cooling output signal in energy saving mode	Active	Inactive ¹⁾

1) Factory setting

Set of DIP switches of RCU61.0 and RCU61.1

DIP switch no.	Meaning	Position ON	Position OFF
1	Operating mode changeover via external switch	Changeover from normal operation or standby to energy saving mode	Changeover from normal operation or energy saving to standby ¹⁾
2	Operating action of switch for external operating mode changeover	Changeover activated when contact of switch is closed (N.O.) ¹⁾	Changeover activated when contact of switch is open (N.C.)
3	Standby	OFF	Frost protection mode (heating output ON at a setpoint of 8 °C) ¹⁾
4	P-band	1 K in heating mode 0.5 K in cooling mode	4 K in heating mode ¹⁾ 2 K in cooling mode ¹⁾
5	Dead zone (Xdz)	2 K ¹⁾	5 K
6	Cooling output signal in energy saving mode	Active	Inactive ¹⁾

1) Factory setting

Description	Type reference
Adapter plate 120 x 120 mm for 4" x 4" conduit boxes	ARG70
Adapter plate 96 x 120 mm for 2" x 4" conduit boxes	ARG70.1
Adapter plate for surface wiring 112x130 mm	ARG70.2

Notes

Check the settings of DIP switches no. 1 through no. 8 of the RCU60 / RCU60.1 and of DIP switches no. 1 through no. 6 of the RCU61.0 / RCU61.1. If setpoint limitation is required, use the minimum and maximum limitation facility (energy saver).

After applying power, the controller makes a reset, which takes about 3 seconds. Then, it will be ready to operate.

Before the controller (RCU61/61.1) starts its control action, it performs a three-position synchronization of the actuator. As a result, the actuator will be fully opened and then closed again. This process takes 400 seconds. Then, the controller will be ready to operate.

The controller is supplied with Mounting Instructions.

Mounting location: on a wall of the room to be heated or cooled. Not in niches or bookshelves, not behind curtains, above or near heat sources and not exposed to direct solar radiation. Mounting height is about 1.5 m above the floor. The connecting wires can be run to the controller from a recessed conduit box.

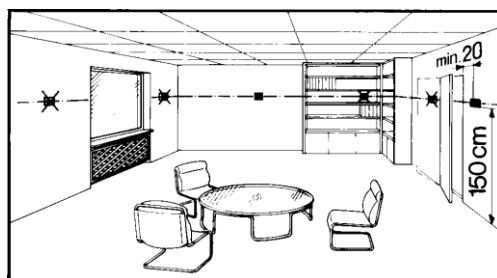

Only authorized personnel may open the controller.

Mounting, installation and commissioning

When mounting the unit, fix the baseplate first. Then, make the electrical connections and fit and secure the cover.

The controller must be mounted on a flat wall and in compliance with local regulations. If there are thermostatic radiator valves in the reference room, they must be set to their fully open position.

Maintenance

The room temperature controller is maintenance-free.

Technical data

Power supply	Operating voltage	AC 24 V ± 20%
	Frequency	50/60 Hz
	Power consumption	max. 6 VA
Functional data	Setpoint setting range	8...30 °C
	Max. control deviation at 25 °C	max. ± 0.7 K
	Switching differential heating SDH or P-band XpH (selectable)	1 K or 4 K
	Switching differential cooling SDC or P-band XpK (selectable)	0.5 K or 2 K
	Setpoint «Energy saving mode C» heating	16 °C

Accessories

Description	Type reference
Adapter plate 120 x 120 mm for 4" x 4" conduit boxes	ARG70
Adapter plate 96 x 120 mm for 2" x 4" conduit boxes	ARG70.1
Adapter plate for surface wiring 112x130 mm	ARG70.2

Notes

Check the settings of DIP switches no. 1 through no. 8 of the RCU60 / RCU60.1 and of DIP switches no. 1 through no. 6 of the RCU61.0 / RCU61.1. If setpoint limitation is required, use the minimum and maximum limitation facility (energy saver).

After applying power, the controller makes a reset, which takes about 3 seconds. Then, it will be ready to operate.

Before the controller (RCU61/61.1) starts its control action, it performs a three-position synchronization of the actuator. As a result, the actuator will be fully opened and then closed again. This process takes 400 seconds. Then, the controller will be ready to operate.

The controller is supplied with Mounting Instructions.

Mounting location: on a wall of the room to be heated or cooled. Not in niches or bookshelves, not behind curtains, above or near heat sources and not exposed to direct solar radiation. Mounting height is about 1.5 m above the floor. The connecting wires can be run to the controller from a recessed conduit box.

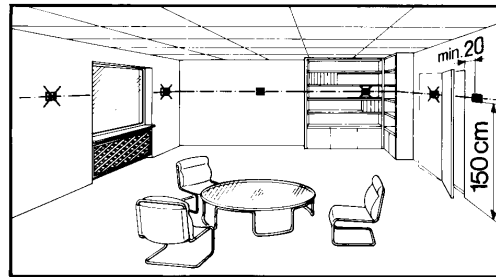

Only authorized personnel may open the controller.

Mounting, installation and commissioning

When mounting the unit, fix the baseplate first. Then, make the electrical connections and fit and secure the cover.

The controller must be mounted on a flat wall and in compliance with local regulations. If there are thermostatic radiator valves in the reference room, they must be set to their fully open position.

Maintenance

The room temperature controller is maintenance-free.

Technical data

Power supply	Operating voltage	AC 24 V \pm 20%
	Frequency	50/60 Hz
	Power consumption	max. 6 VA
Functional data	Setpoint setting range	8...30 °C
	Max. control deviation at 25 °C	max. \pm 0.7 K
	Switching differential heating SDH or P-band XpH (selectable)	1 K or 4 K
	Switching differential cooling SDC or P-band XpK (selectable)	0.5 K or 2 K
	Setpoint «Energy saving mode C» heating	16 °C

以上内容仅为本文档的试下载部分，为可阅读页数的一半内容。如要下载或阅读全文，请访问：<https://d.book118.com/796023125003010105>