

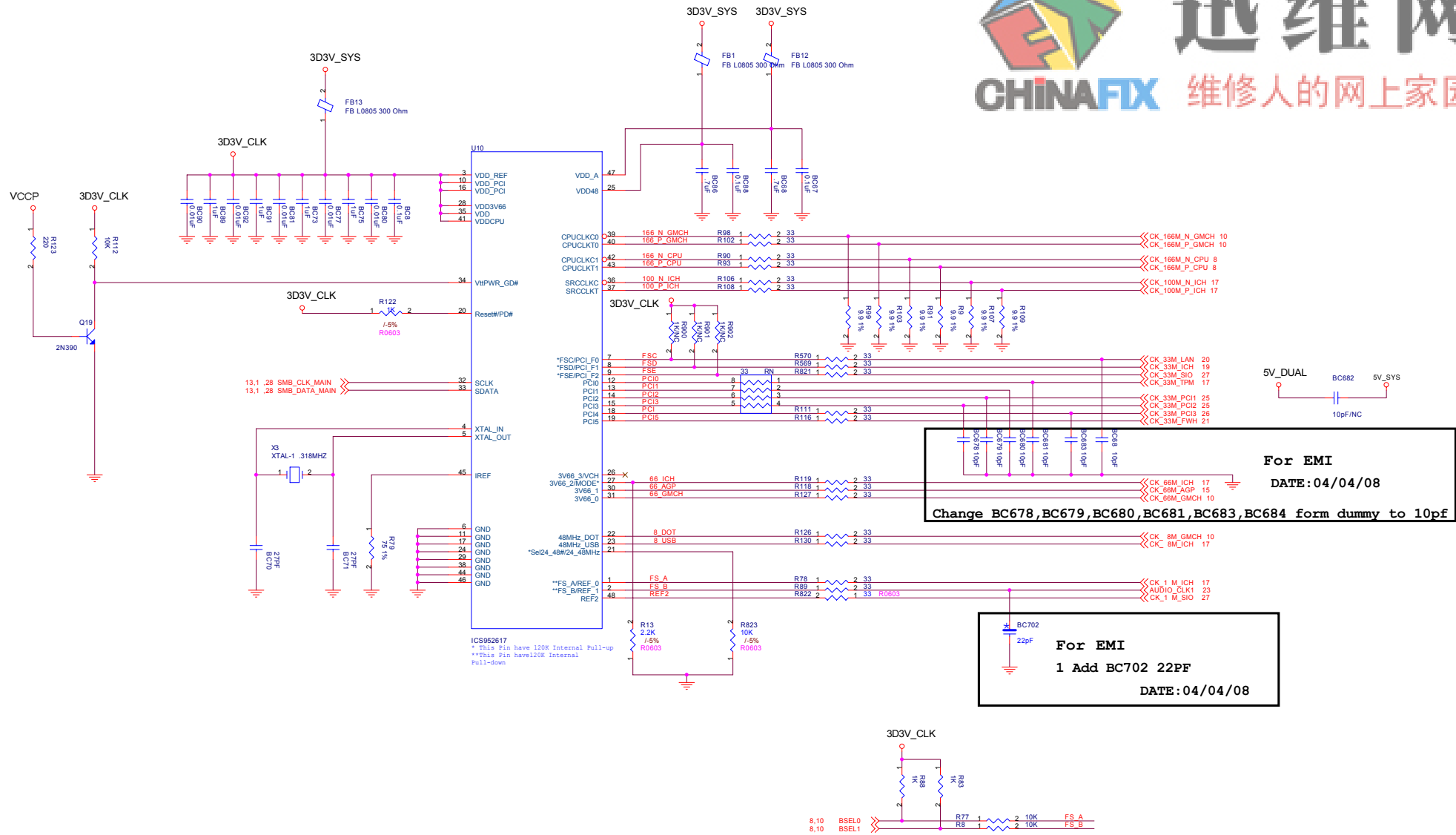

迅维网

CHINAFOX

维修人的网上家园



For EMI
DATE: 04/04/08
 Change BC678, BC679, BC680, BC681, BC683, BC684 form dummy to 10pf

For EMI
 1 Add BC702 22PF
DATE: 04/04/08

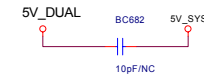

FOXCONN PCEG

Title		Clock Generator CK-409	
Size	Document Number	865M08	
Date	Saturday, April 10, 2008	Sheet	3 of 30

Semtech PWM for Intel P4 VRM10 Power

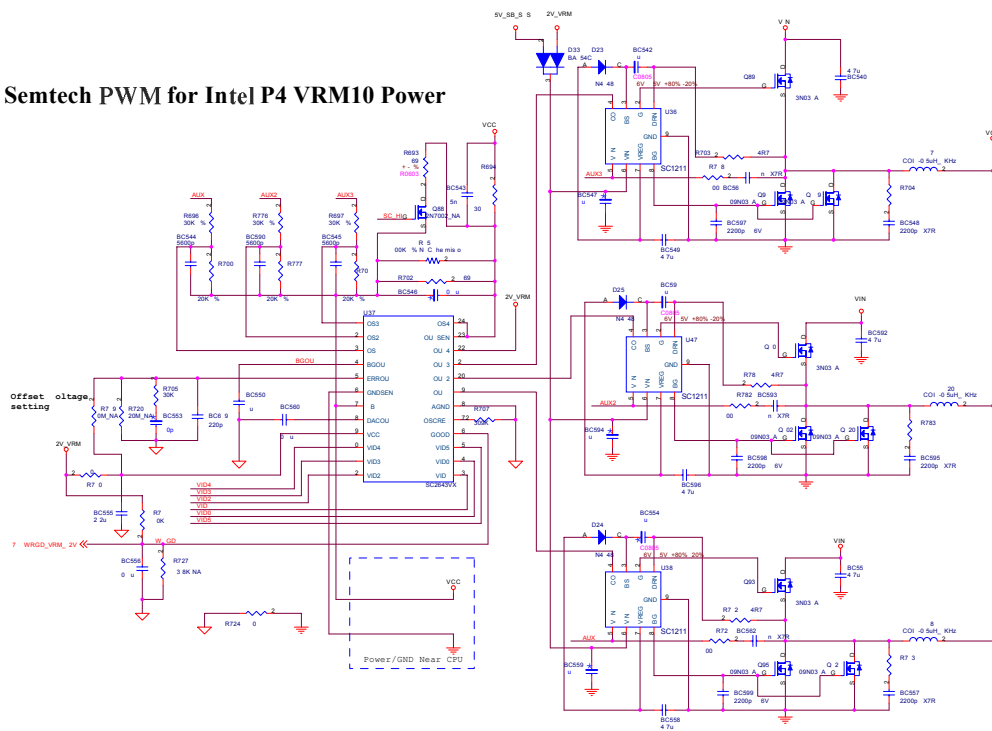

迅维网

维修人的网上家园

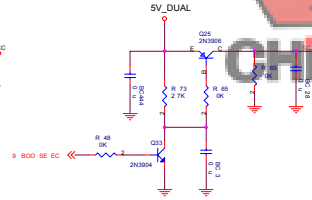

ATX12V_POWER_CONNECTOR

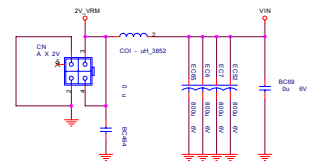

Change list

- | For loadline test | DATE:04/04/08 |
|--|---------------|
| 1 R693 change from 200 Ohm to 169 Ohm | |
| 2 R702 change from 147 Ohm to 169 Ohm | |
| 3 BC546 change from 0.47uF to 0.1uF | |
| 4 BC553 change from 220pF to 10pF | |
| 5 L17,L18,L20 change from 1.1uH@1KHz to 0.5uH@1KHz | |

VCC_VID & VIDGD

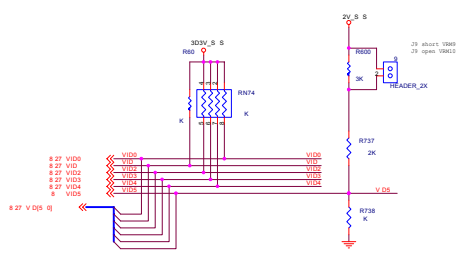
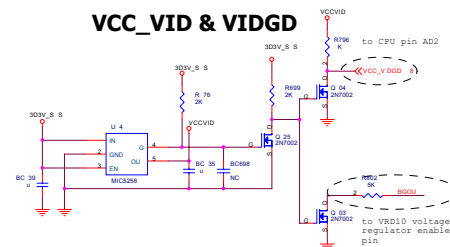

VID5	
0-3V for VR10	J9 open VRM10/VRD10 1
3-7V for VR9	J9 short VRM9



2D5V_STR Regulator

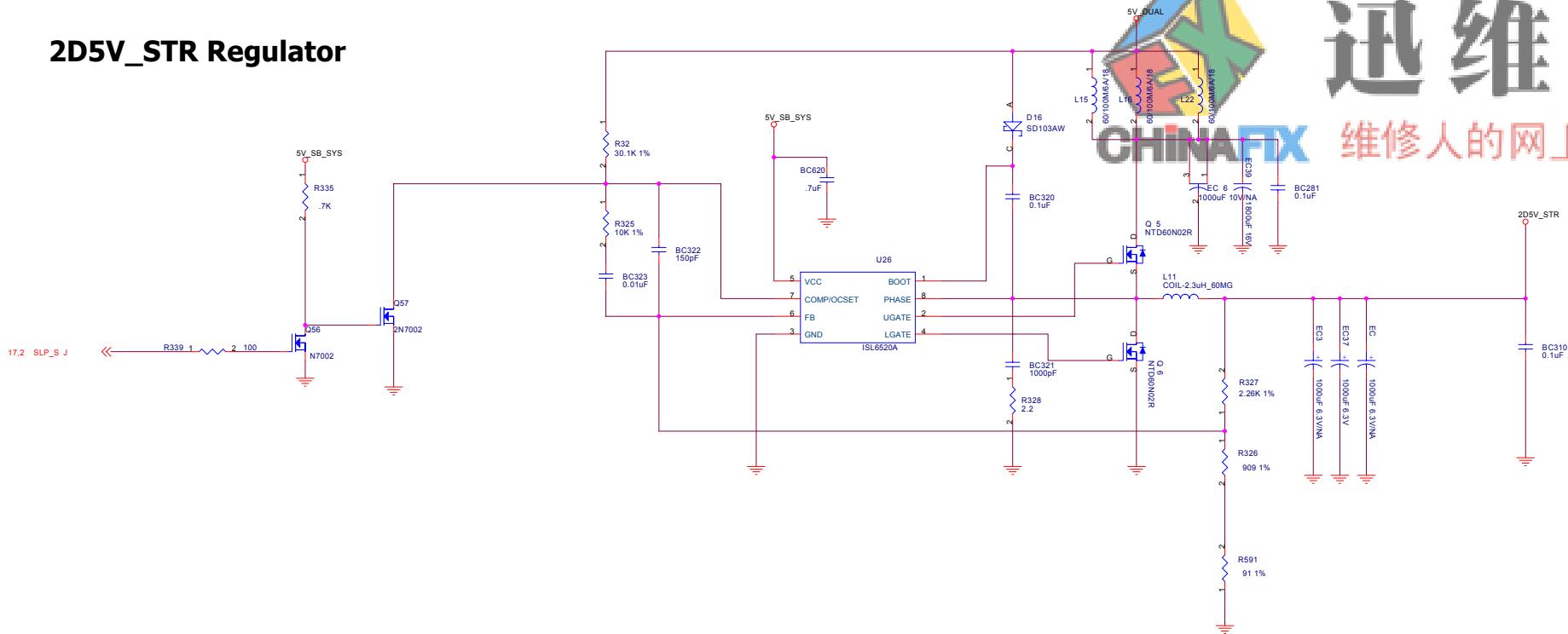

5V_DUAL Circuit

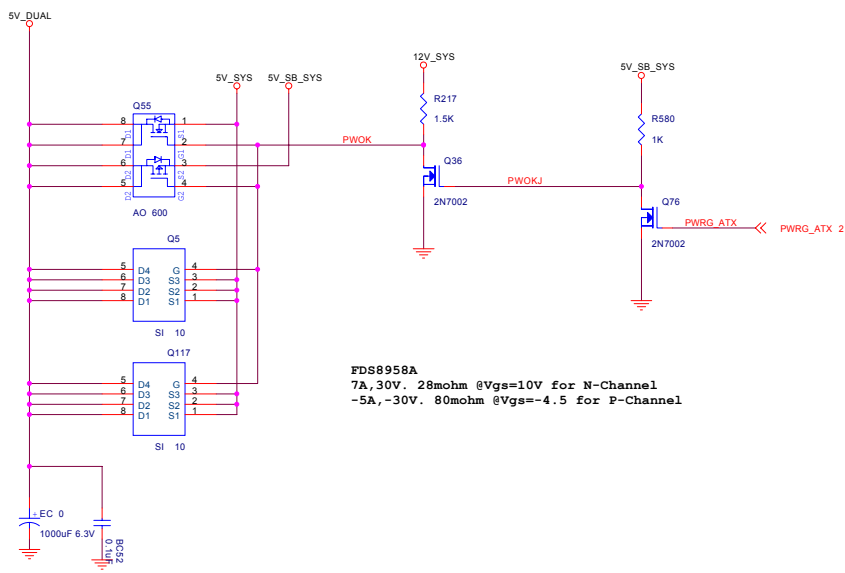

3D3V_SV Regulator

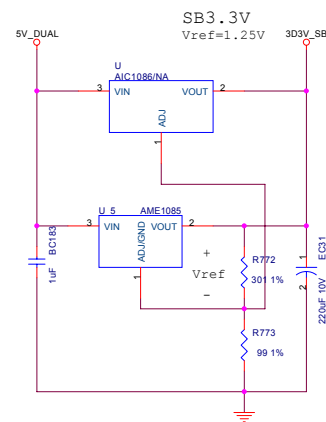

$$V_{out} = V_{ref} (1 + R2/R1) + I_{adj} R2$$

R1 is Up Resister.
 Iadj=50uA
 Vref=1.25V

Change list

1 U45 change from AIC1086 SOT223 to AME1085 TO252

DATE: 04/04/08



FOXCONN PCEG

Title		
Power 2.5V-5VDUAL-3.3SB		
Size	Document Number	Rev
C	865M08	C
Date:	Saturday, April 10, 2008	Sheet 5 of 30



CHINAFOX

迅维网

维修人的网上家园

1D5V_CORE Regulator

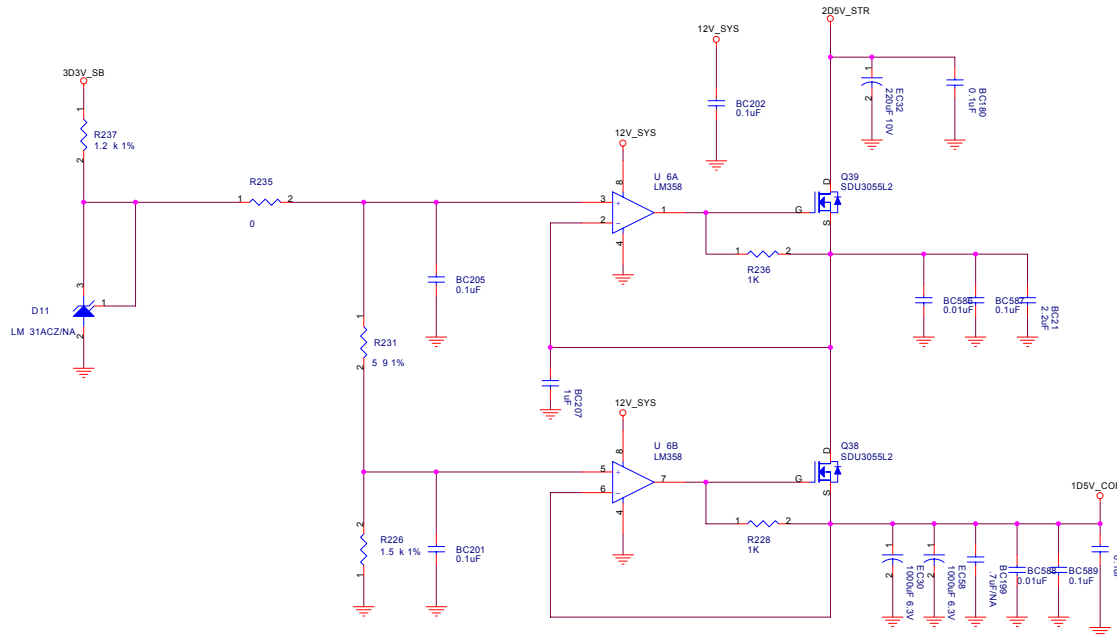

FOXCONN

FOXCONN PCEG

File	Power 1.5V	
Size	Document Number	Rev
C	865M08	C
Date:	Saturday, April 10, 200	Sheet 6 of 30

GMCH_VTT Regulator

NWD=1.45V
 PSC=1.2V
 GMCH VTT Source 1.6A and Sink 600mA



迅维网

维修人的网上家园

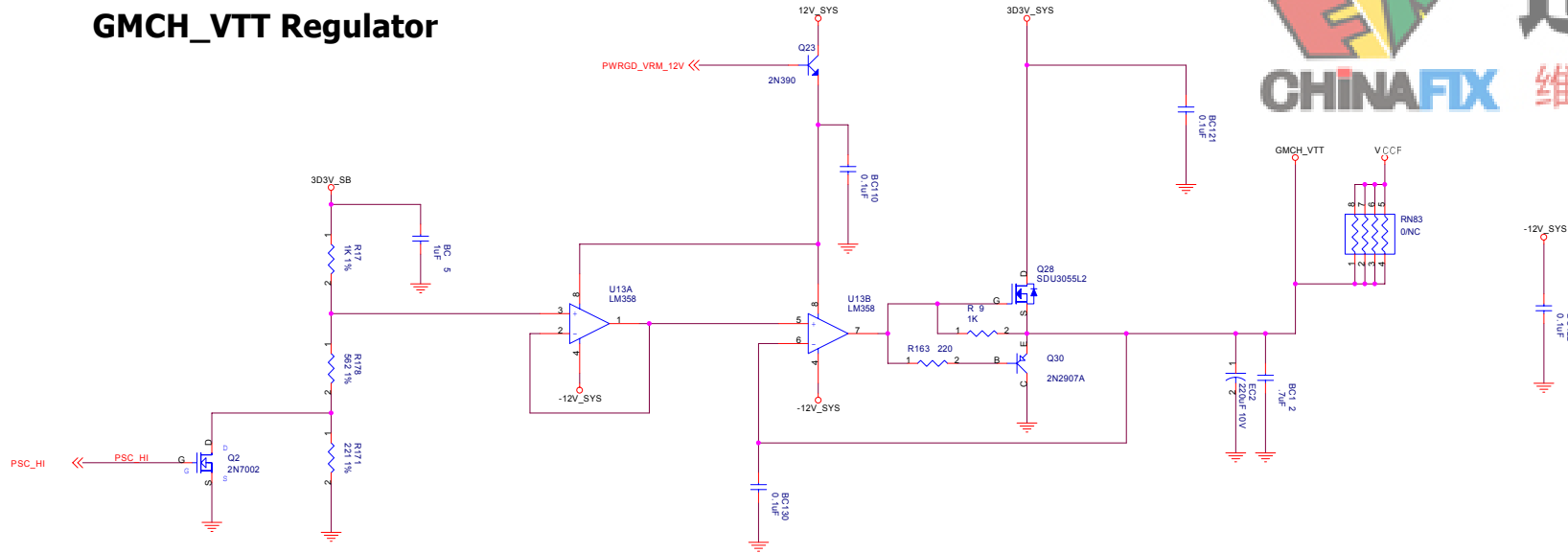

Change list

DATE: 04/04/08

- 1 add Q24
- 2 add R171
- 3 add R178
- 4 add R174
- 5 add BC445
- 6 add U13
- 7 add BC130, BC110, BC121, BC122
- 8 add Q23
- 9 add R163, R494
- 10 add Q28, Q30
- 11 add BC142, EC24
- 12 Dummy RN83

VTT_DDR Regulator

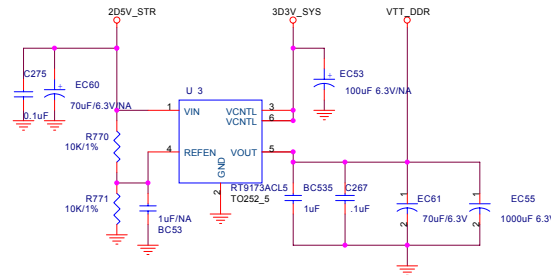

FOXCONN PCEG

Title		Power 1.25V-GMCH VTT
Size	Document Number	865M08
Date	Saturday, April 10, 2008	Sheet 7 of 30

HOST BUS



CMD ADDRESS & VID

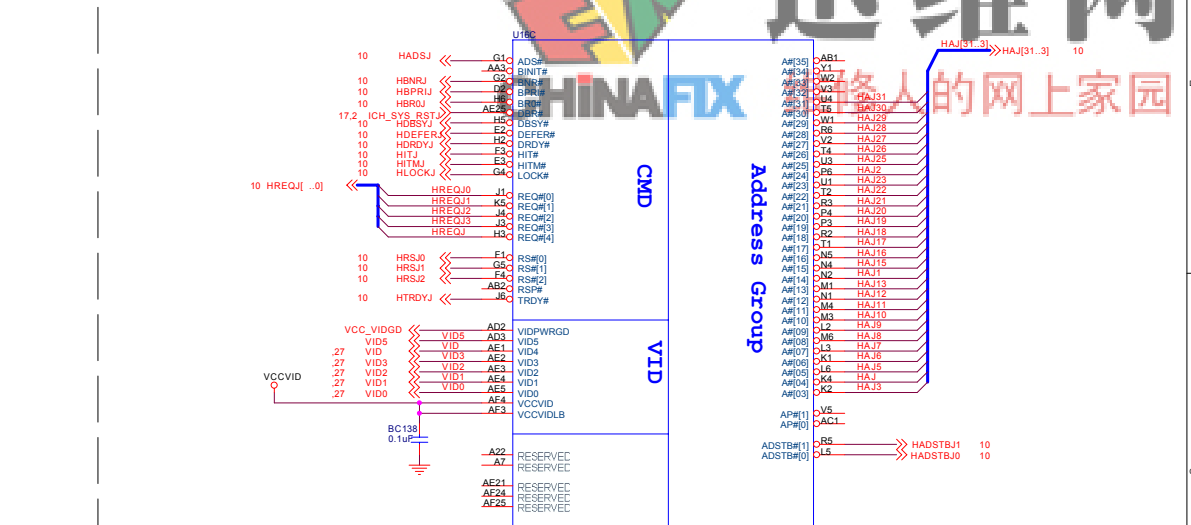
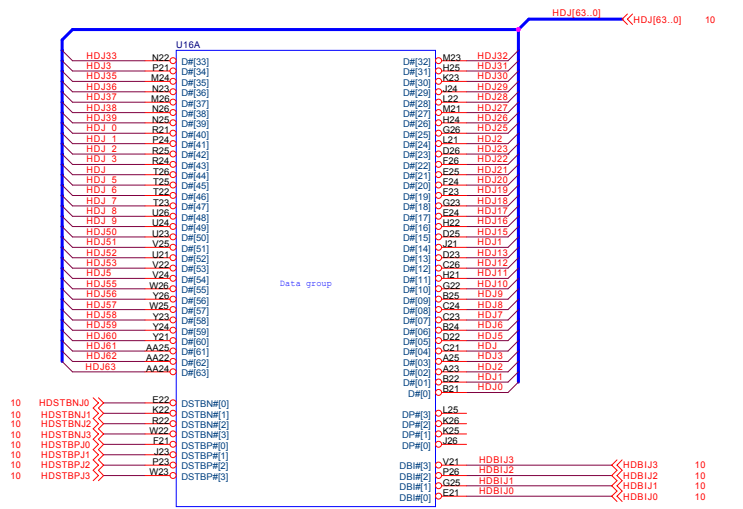

TEST, ICH5, CLK & THERMAL

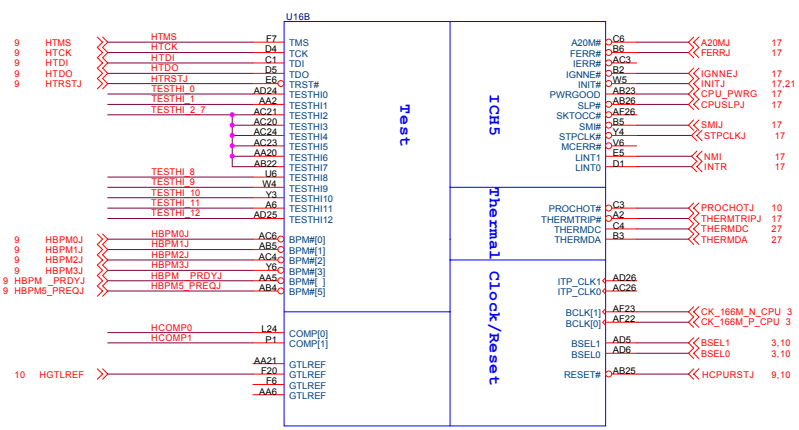

PULL UP CIRCUIT

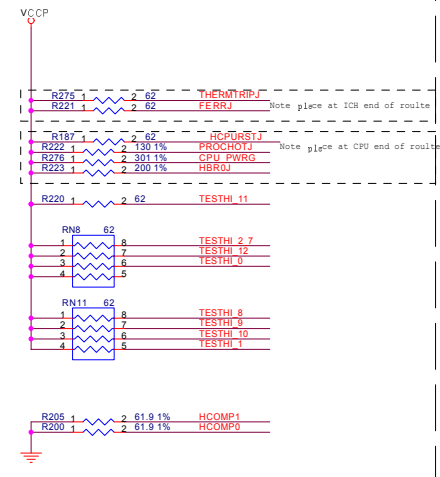

HOST GTLREF

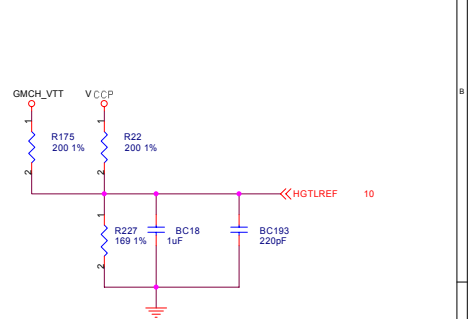

FOXCONN
FOXCONN PCEG

File: Socket 478-1

Size C Document Number: 865M08 Rev C

Date: Saturday, April 10, 2009 Sheet 8 of 30

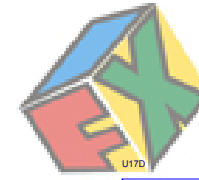

迅维网

维修的网上家园

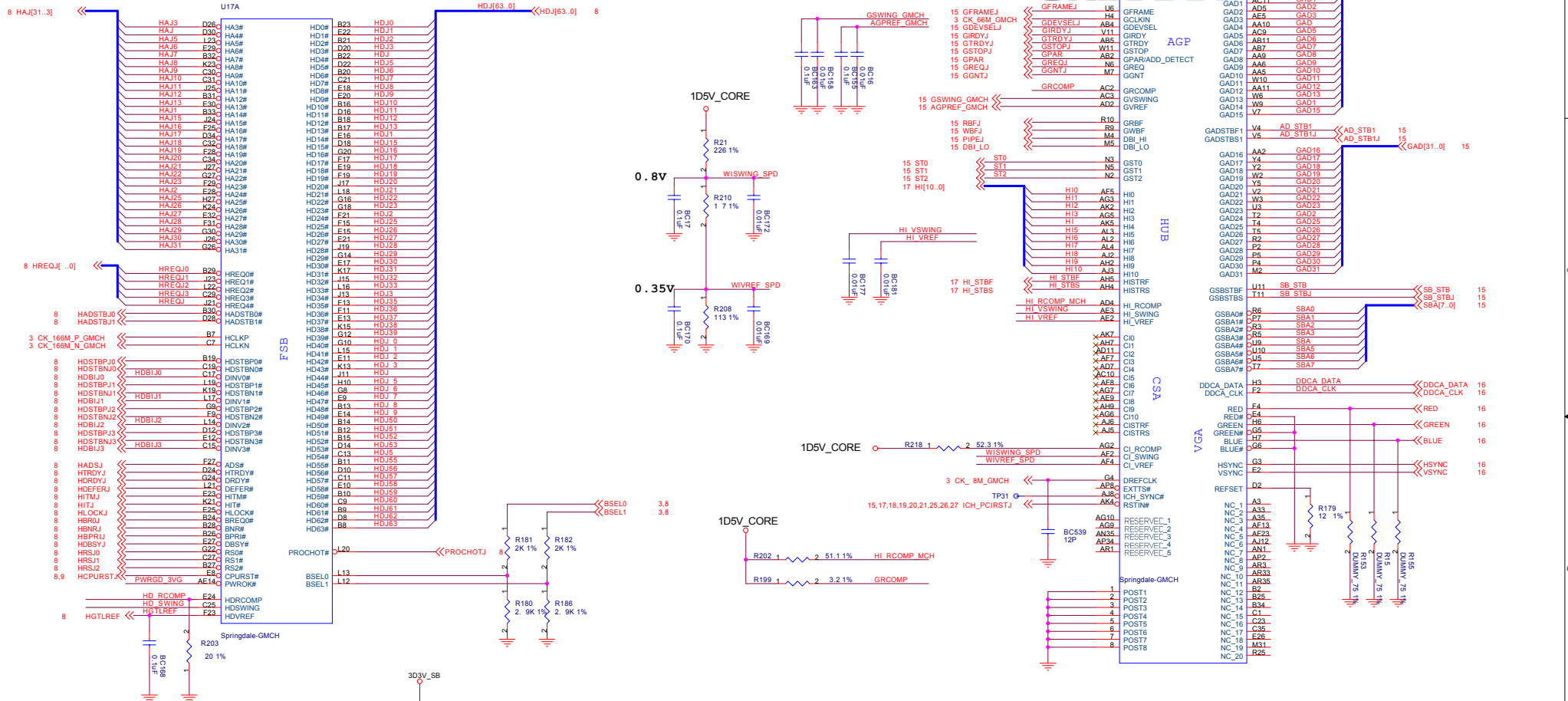

Change list

DATE: 04/04/08

1 R270 change from 226 ohm to 249 ohm

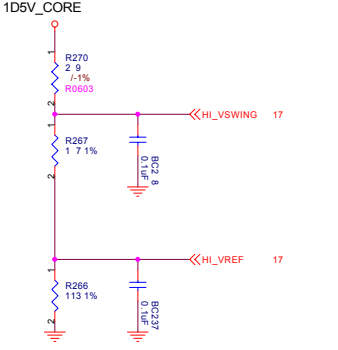
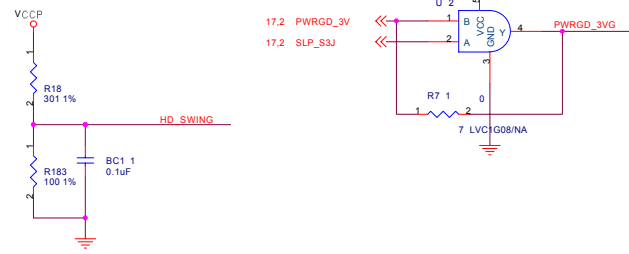

FOXCONN

FOXCONN PCEG

file: **GMCH-1**

Size	Document Number	Rev
C	865M08	C

Date: Saturday, April 10, 2008 Sheet 10 of 30

以上内容仅为本文档的试下载部分，为可阅读页数的一半内容。如要下载或阅读全文，请访问：<https://d.book118.com/838012047040006073>